

Stereo Audio Volume Controller With Soft Steps, 4 Stereo(1 quasi-differential) Inputs, Low voltage, Gain/Loss, Low power consumption.

FEATURES

- Operation range: 2.5V~6.5V.
- One quasi-differential input.
- Input Gain: 0dB ~ +15dB.
- Soft step volume control : -79dB ~ +15dB.
- Low power consumption.
- Good PSRR and low pop noise.
- I²C interface.
- Housed in 16 pin SSOP packages.

APPLICATIONS

- Multimedia system
- Hi-Fi audio system.
- Bluetooth.
- DAB

DESCRIPTION

The MS6274 is a stereo audio volume controller IC with 4 sets of stereo inputs(1 quasi-differential Input). It has Input gain(0 ~ +15dB), Soft step volume control(-79dB ~ +15dB) with programmable blend times. It uses CMOS technology specially for the low voltage application with low noise, rail-to-rail output.

BLOCK DIAGRAM

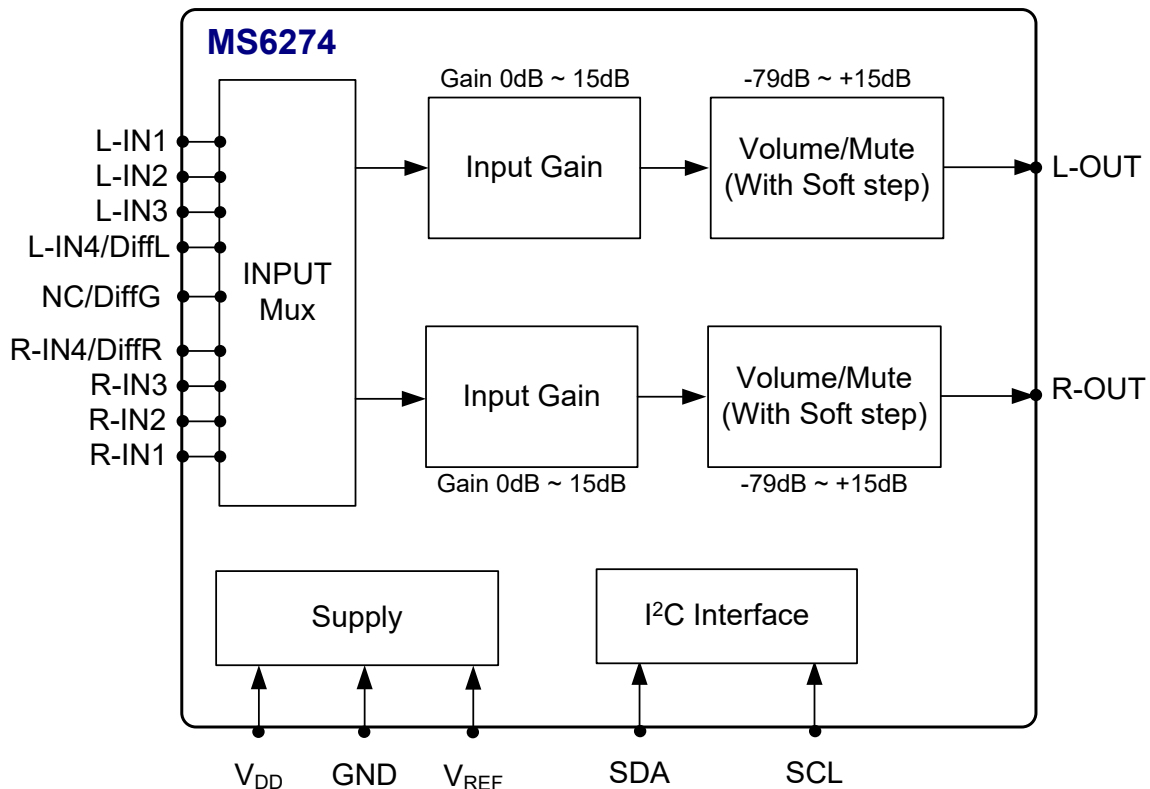

PIN CONFIGURATION

Symbol	Pin	Description
NC/DIFFG	1	No Connected /Differential Stereo Input Common
L-IN4/DIFFL	2	4 th Left Channel Input / Left Differential Stereo Input
L-IN3	3	3 rd Left Channel Input
L-IN2	4	2 nd Left Channel Input
L-IN1	5	1 st Left Channel Input
L-OUT	6	Left Channel Output
V _{SS}	7	Ground
SDA	8	I ² C Data Input
SCL	9	I ² C Clock Input
V _{DD}	10	Positive Supply Voltage
R-OUT	11	Right Channel Output
R-IN1	12	1 st Right Channel Input
R-IN2	13	2 nd Right Channel Input
R-IN3	14	3 rd Right Channel Input
R-IN4/DIFFR	15	4 th Right Channel Input / Right Differential Stereo Input
V _{REF}	16	Reference Voltage = 1/2V _{DD}

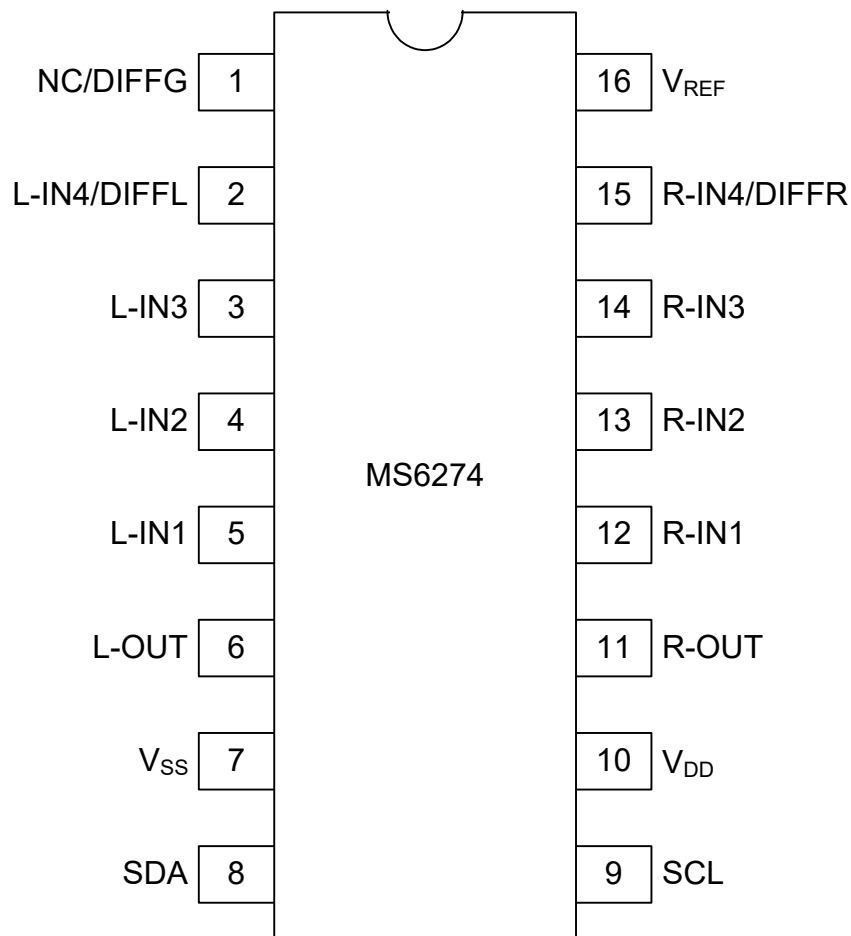

ORDERING INFORMATION

Package	Part number	Packaging Marking	Transport Media
16-Pin SSOP (lead free)	MS6274SSGTR	MS6274G	2.5k Units Tape and Reel
16-Pin SSOP (lead free)	MS6274SSGU	MS6274G	100 Units Tube

RoHS Compliance

ABSOLUTE MAXIMUM RATINGS

Symbol	Parameter	Rating	Unit
V _{DD}	Supply Voltage	6.5	V
V _{ESD}	Electrostatic Handling	-3000 to 3000	V
T _{STG}	Storage Temperature Range	-65 to 150	°C
T _A	Operating Ambient Temperature Range	-40 to 85	°C
T _J	Maximum Junction Temperature	120	°C
T _S	Soldering Temperature, 10 seconds	260	°C
R _{THJA}	Thermal Resistance from Junction to Ambient in Free Air SSOP16	115.9	°C/W

OPERATING RATINGS

Symbol	Parameter	Min	Typ	Max	Unit
V _{DD}	Supply Voltage	2.5	-	6.5	V

5V ELECTRICAL CHARACTERISTICS

(T_a=25°C, All stages 0dB, f=1kHz, C_{REF}=1uF, refer to the application circuit; unless otherwise specified)

Symbol	Parameter	Conditions	Min	Typ	Max	Unit
Supply						
I _Q	Quiescent Current	V _{IN} =0V	-	4.2	-	mA
I _{PD}	Power down current	V _{IN} =0V	-	120	-	uA
PSRR	Power Supply Rejection Ratio	C _{REF} = 1uF, f = 100Hz	55	58	-	dB
Input Selectors						
R _{IN}	Input Resistance	Input 1,2,3,4		100		kΩ
R _{IN-Diff}	Input Resistance	Differential		100		kΩ
G _{IN}	Input Gain Range	Gain	0	-	15	dB
G _{STEP}	Step Resolution		-	1	-	dB
ERR _G	Gain Setting error		-0.2	0	0.2	dB
CMRR	Common mode rejection ratio	V _{CM} = 1V _{rms} @ 1KHz	40	55	-	dB
		V _{CM} = 1V _{rms} @ 10KHz	40	55	-	dB

Volume control						
CR _{VOL}	Volume Control Range	Attenuation & Gain	-79	-	+15	dB
RES _{VOL}	Volume Step Resolution		-	1	-	dB
ERR _{VOL}	Volume Setting Error	A _v = +15 to -40dB	-0.5	0	1	dB
		A _v = -40 to -79dB	-1	0	5	dB
MUTE	Mute Attenuation	V _{in} =0dBV		-90		dB
General						
VO _{MAX}	Maximum Output Voltage Swing	(THD+N)/S <0.1%	-	1.59	-	V _{rms}
THD+N	Total Harmonic Distortion Plus Noise	V _{OUT} = 1V _{rms}	-	-75	-	dB
			-	0.0177	-	%
S/N	Signal-to-Noise Ratio	V _{OUT} = 1V _{rms}	-	93	-	dB
CS	Channel Separation Left/Right		90	94	-	dB
Bus Input						
V _{IH}	Bus High Input Level		1.8	-	-	V
V _{IL}	Bus Low Input Level		-	-	0.8	V

3.3V ELECTRICAL CHARACTERISTICS

(T_a=25°C, All stages 0dB, f=1kHz, C_{REF} =1uF, refer to the application circuit; unless otherwise specified)

Symbol	Parameter	Conditions	Min	Typ	Max	Unit
Supply						
I _Q	Quiescent Current	V _{IN} =0V	-	3.6	-	mA
I _{PD}	Power down current	V _{IN} =0V	-	80	-	uA
PSRR	Power Supply Rejection Ratio	C _{REF} = 1uF, f = 100Hz	65	70	-	dB
General						
VO _{MAX}	Maximum Output Voltage Swing	(THD+N)/S <0.1%	-	1	-	V _{rms}
THD+N	Total Harmonic Distortion Plus Noise	V _{OUT} = 0.707V _{rms}	-	-70	-	dB
			-	0.03	-	%
S/N	Signal-to-Noise Ratio	V _{OUT} = 0.707V _{rms}	-	90	-	dB
CS	Channel Separation Left/Right		90	93	-	dB

2.5V ELECTRICAL CHARACTERISTICS

(T_a=25°C, All stages 0dB, f=1kHz, C_{REF} =1uF, refer to the application circuit; unless otherwise specified)

Symbol	Parameter	Conditions	Min	Typ	Max	Unit
Supply						
I _Q	Quiescent Current	V _{IN} =0V	-	3.3	-	mA
I _{PD}	Power down current	V _{IN} =0V	-	60	-	uA
PSRR	Power Supply Rejection Ratio	C _{REF} = 1uF, f = 100Hz	60	65	-	dB
General						
VO _{MAX}	Maximum Output Voltage Swing	(THD+N)/S <0.1%	-	0.8	-	V _{rms}
THD+N	Total Harmonic Distortion Plus Noise	V _{OUT} = 0.707V _{rms}	-	-67	-	dB
			-	0.04	-	%
S/N	Signal-to-Noise Ratio	V _{OUT} = 0.707V _{rms}	-	90	-	dB
CS	Channel Separation Left/Right		90	93	-	dB

TYPICAL PERFORMANCE CHARACTERISTICS

($T_a=25^\circ\text{C}$, $R_L=10\text{k}\Omega$, $C_{\text{REF}}=1\mu\text{F}$; unless otherwise specified)

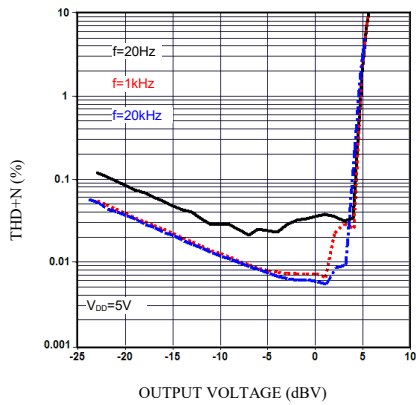

THD+N vs. output voltage

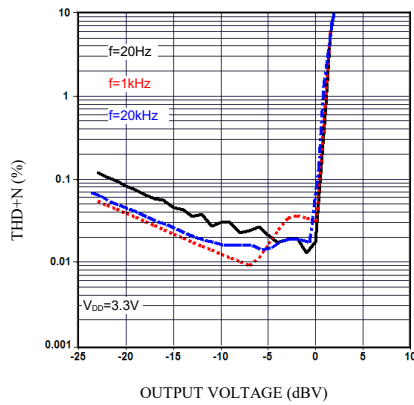

THD+N vs. output voltage

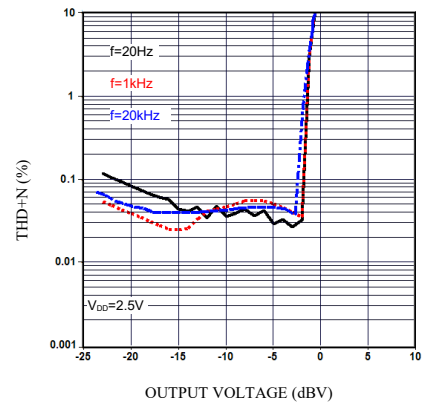

THD+N vs. output voltage

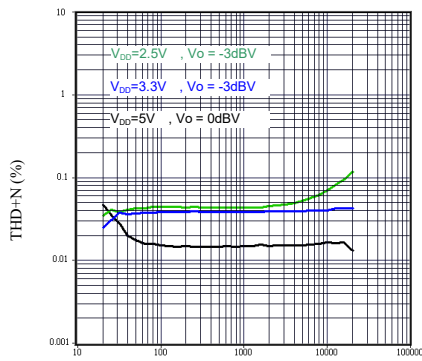

THD+N vs. frequency

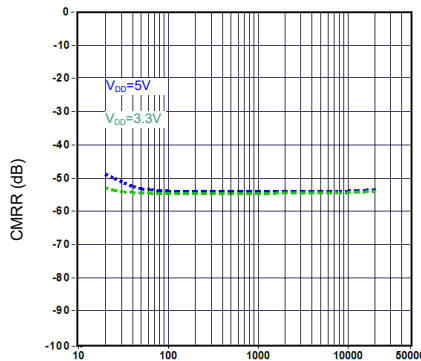

CMRR vs. frequency

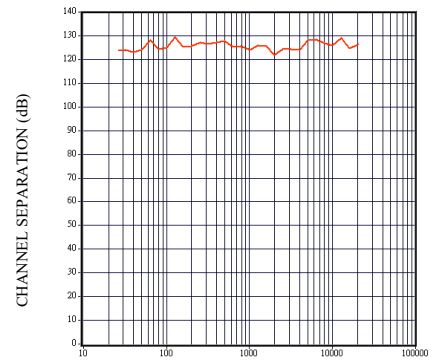

Channel separation vs. frequency

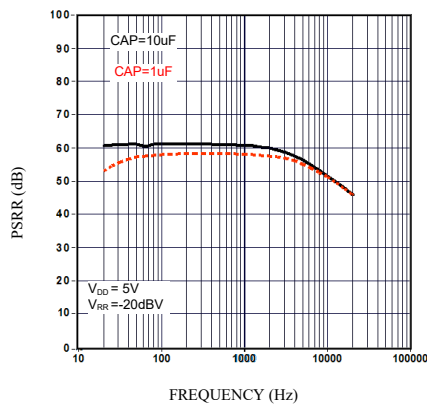

PSRR vs. frequency

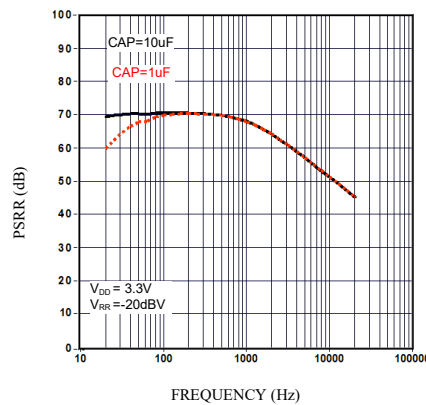

PSRR vs. frequency

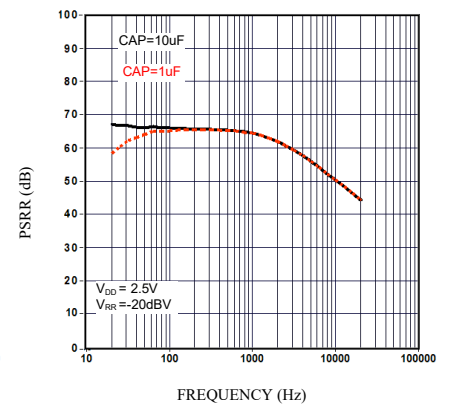

PSRR vs. frequency

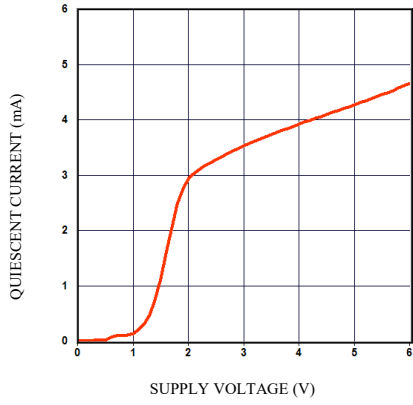

Quiescent current vs. supply voltage

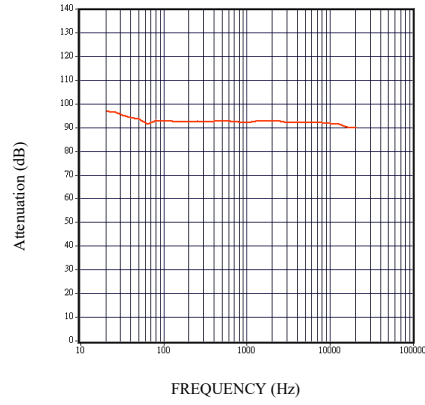

Mute vs. frequency

I²C BUS DESCRIPTION

Start and stop conditions

A start condition is activated when the SCL is set to HIGH and SDA shifts from HIGH to LOW state. The stop condition is activated when SCL is set to HIGH and SDA shifts from LOW to HIGH state. Please refer to the timing diagram below.

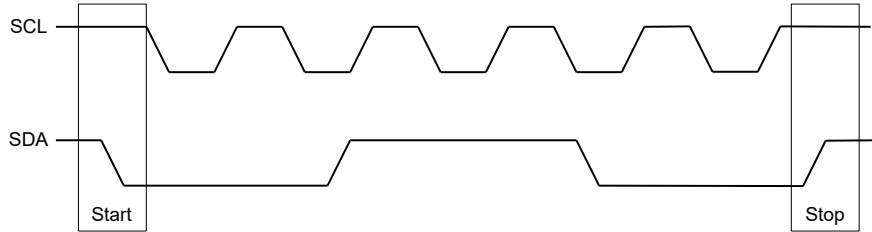

SCL : Serial Clock Line, SDA : Serial Data Line

Data validity

A data on the SDA line is considered valid and stable only when the SCL signal is in HIGH state. The HIGH and LOW states of the SDA line can only change when the SCL signal is LOW. Please refer to the figure below.

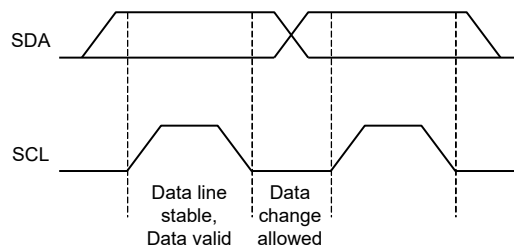

Byte format

Every byte transmitted to the SDA line consists of 8 bits. Each byte must be followed by an acknowledge bit. The MSB is transmitted first.

Acknowledge

During the Acknowledge clock pulse, the master (up) put a resistive HIGH level on the SDA line. The peripheral (audio processor) that acknowledges has to pull-down (LOW) the SDA line during the Acknowledge clock pulse so that the SDA line is in a stable LOW state during this clock pulse. Please refer to the diagram below.

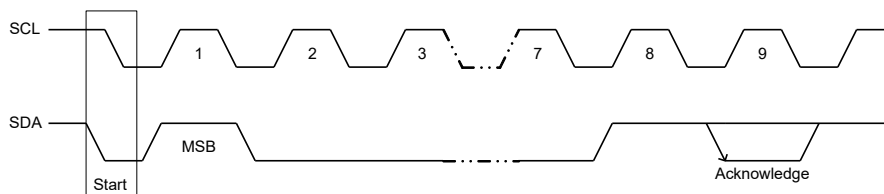

The audio processor that has been addressed has to generate an Acknowledge after receiving each byte, otherwise, the SDA line will remain at the HIGH level during the ninth (9th) clock pulse. In this case, the master transmitter can generate the STOP information in order to abort the transfer.

BUS INTERFACE

Data are transmitted to and from the MCU to the MS6274 via the SDA and SCL. The SDA and SCL make up the BUS interface. It should be noted that pull-up resistors must be connected to the positive supply voltage.

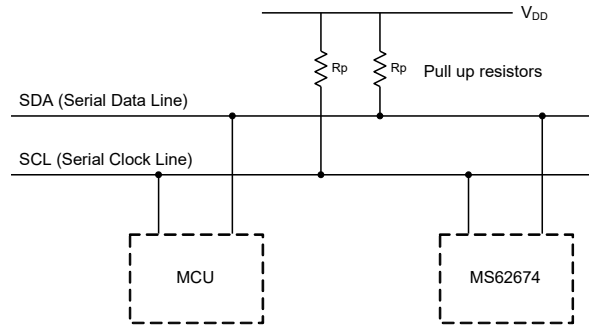

Interface protocol

The format consists of the following

- A START condition
- A chip address byte including the MS6274 address. (7bits)
- The 8th bit of the byte must be “0”.
- The MS6274 must always acknowledge the end of each transmitted byte.
- A data sequence (N-bytes + Acknowledge)
- A STOP condition

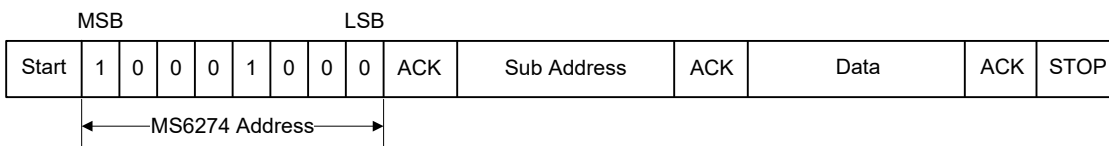

Chip Address

The chip address of the MS6274 is 88H.

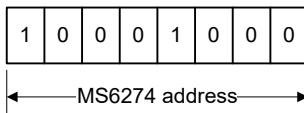

SubAddress

MSB				LSB				Function
A7	A6	A5	A4	A3	A2	A1	A0	
0	0	0	0	0	0	0	0	Soft-step time / ON/OFF , SE/DIFF Selector
0	0	0	0	0	0	0	1	L-channel Input selector / Input Gain Control
0	0	0	0	0	0	1	0	R-channel Input selector / Input Gain Control
0	0	0	0	0	0	1	1	Both channels Input selector / Input Gain Control
0	0	0	0	0	1	0	0	L-channel Volume Control
0	0	0	0	0	1	0	1	R-channel Volume Control
0	0	0	0	0	1	1	0	Both channels Volume Control
0	0	0	0	0	1	1	1	Power management

Soft-step time / ON / OFF , SE/DIFF Selector (0H)

MSB							LSB		Function
D7	D6	D5	D4	D3	D2	D1	D0		
					0	0	0	Soft-step Time 0.64ms	
					0	0	1	1.28ms	
					0	1	0	2.56ms	
					0	1	1	5.12ms	
					1	0	0	10.24ms	
					1	0	1	20.48ms	
					1	1	0	40.96ms	
					1	1	1	81.92ms	
				0				Soft-step On	
				1				Off	
0								SE/DIFF Differential	
1								Single-ended	

The initial condition is Single-ended, Soft-step Off, Soft-step time 40.96ms.

Input selector & Gain Control (01H , 02H , 03H)

MSB							LSB		Function
D7	D6	D5	D4	D3	D2	D1	D0		
		0	0					Input selector IN 1	
		0	1					IN 2	
		1	0					IN 3	
		1	1					IN 4 / DIFF	
				0	0	0	0	Input Gain 0dB	
				0	0	0	1	1dB	
				0	0	1	0	2dB	
				0	0	1	1	3dB	
				0	1	0	0	4dB	
				0	1	0	1	5dB	
				0	1	1	0	6dB	
				0	1	1	1	7dB	
				1	0	0	0	8dB	
				1	0	0	1	9dB	
				1	0	1	0	10dB	
				1	0	1	1	11dB	
				1	1	0	0	12dB	
				1	1	0	1	13dB	
				1	1	1	0	14dB	
				1	1	1	1	15dB	

The initial condition is IN4, 14dB. We suggest the gain is set as the power is up. For example, set and fix the gain +10dB, the volume range will be controlled from -69dB to +25dB.

Volume Control (04H , 05H , 06H)

MSB							LSB		Function
D7	D6	D5	D4	D3	D2	D1	D0		
	0	0	0	1	1	1	1	+15dB	
	0	0	0	1	1	1	0	+14dB	
	:	:	:	:	:	:	:	:	
	0	0	0	0	0	0	0	0dB	
	0	0	1	0	0	0	0	0dB	
	0	0	1	0	0	0	1	-1dB	
	:	:	:	:	:	:	:	:	
	0	0	1	1	1	1	1	-15dB	
	0	1	0	0	0	0	0	-16dB	
	:	:	:	:	:	:	:	:	
	0	1	0	1	1	1	1	-31dB	
	0	1	1	0	0	0	0	-32dB	
	:	:	:	:	:	:	:	:	
	0	1	1	1	1	1	1	-47dB	
	1	0	0	0	0	0	0	-48dB	
	:	:	:	:	:	:	:	:	
	1	0	0	1	1	1	1	-63dB	
	1	0	1	0	0	0	0	-64dB	
	:	:	:	:	:	:	:	:	
	1	0	1	1	1	1	1	-79dB	
	1	1	X	X	X	X	X	Mute	

The initial condition is Mute.

Power management (07H)

MSB							LSB		Function
D7	D6	D5	D4	D3	D2	D1	D0		
							0	Release of V_{REF} to GND.	
							1	Set the voltage of V_{REF} to middle of supply voltage.	
					0	X		All devices Active	
					1	1		Power down	

The initial condition is Power down , $V_{REF} = GND$.

Example

Soft-step Time 10.24ms , Soft-step ON , Single-ended Mode.

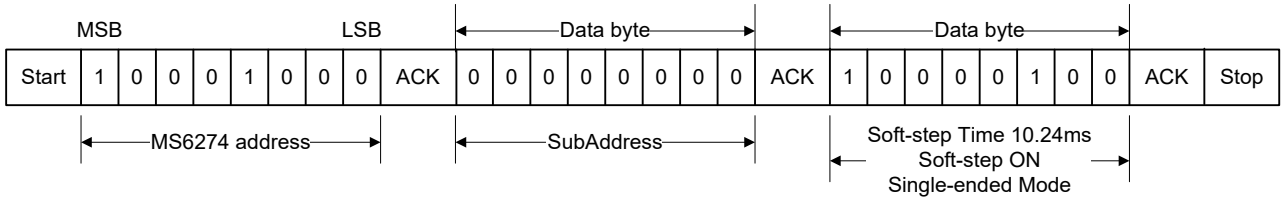

Set the $1/2V_{DD}$, All device active.

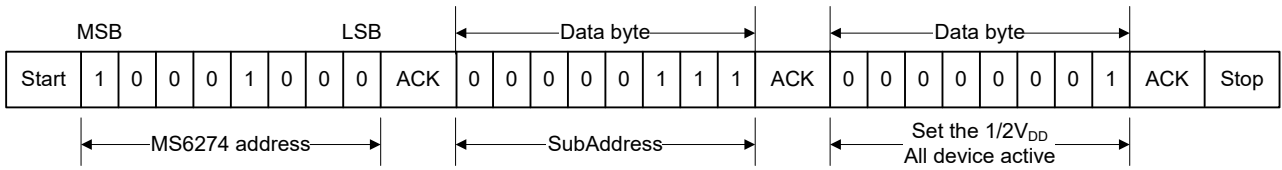

Set Input gain of both channels at +4dB , select Input as IN1.

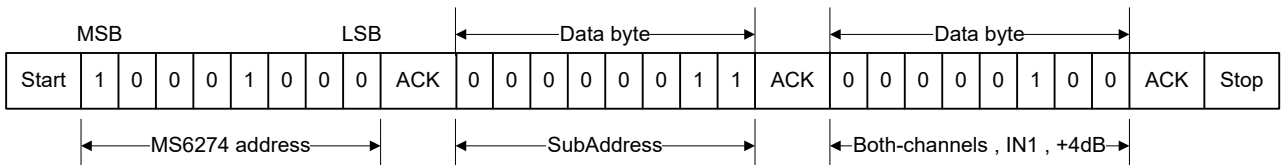

Set Volume of both-channels at -15dB

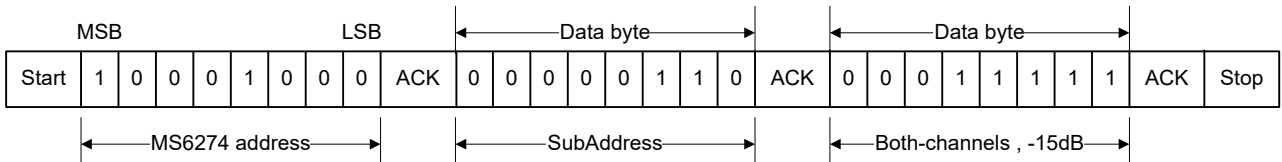

Soft-step volume

When the volume-level is changed audible clicks could appear at the output. The root cause of those clicks could be the sudden change of the envelope of the audio signal. With the Soft-step feature, this click could be reduced to a minimum. Soft-step supports N dB volume change, including mute.

Example

Soft-Step Time = 5.12ms

0dB → -16dB → 0dB

$V_{in} = 1V_{rms} @ 1KHz$

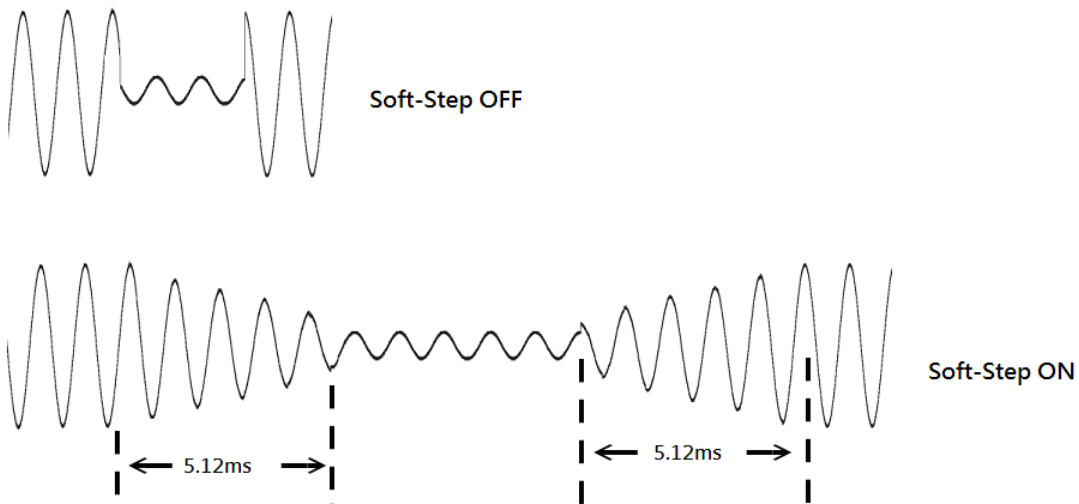

$V_{in} = 1V_{rms} @ 2KHz$

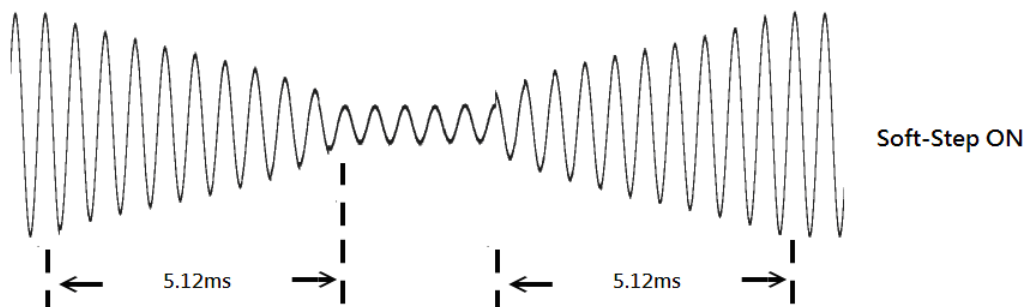

+8dB → -16dB → +8dB

$V_{in} = 0.5V_{rms} @ 1KHz$

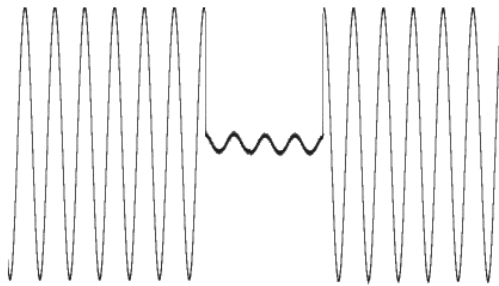

Soft-Step OFF

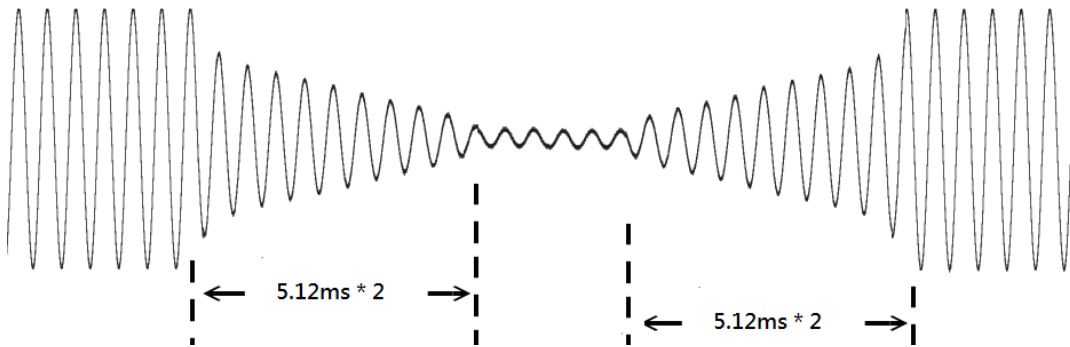

Soft-Step ON

0dB → Mute → 0dB

$V_{in} = 1V_{rms} @ 1KHz$

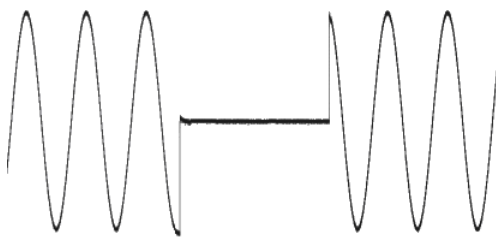

Soft-Step OFF

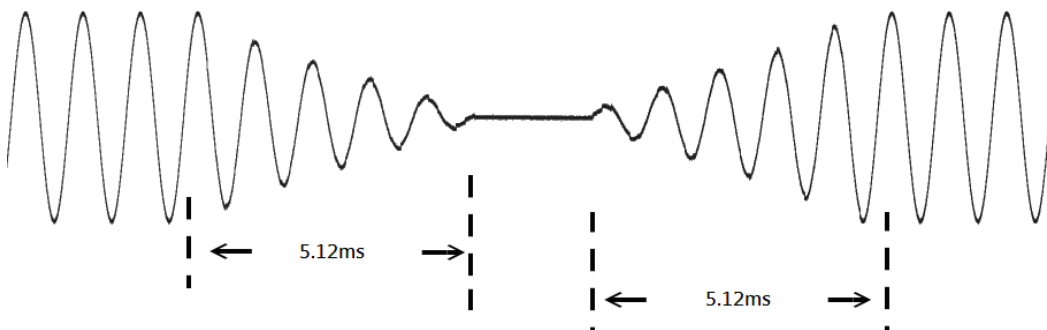

Soft-Step ON

APPLICATION INFORMATION

Basic application example(Single-ended Mode)

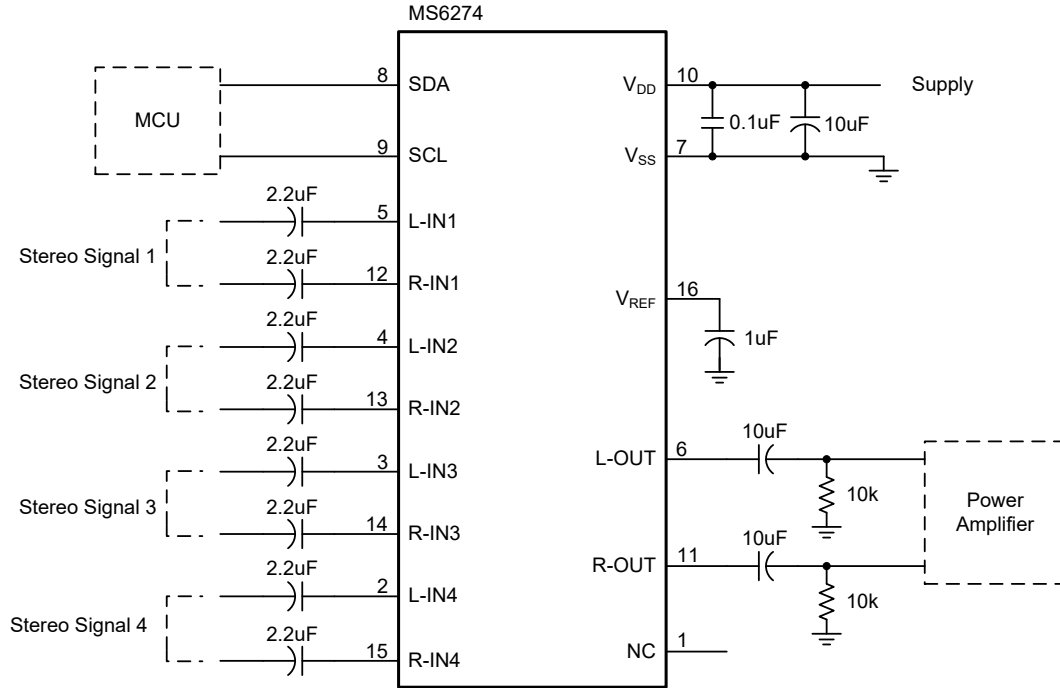

Basic application example(Differential Mode)

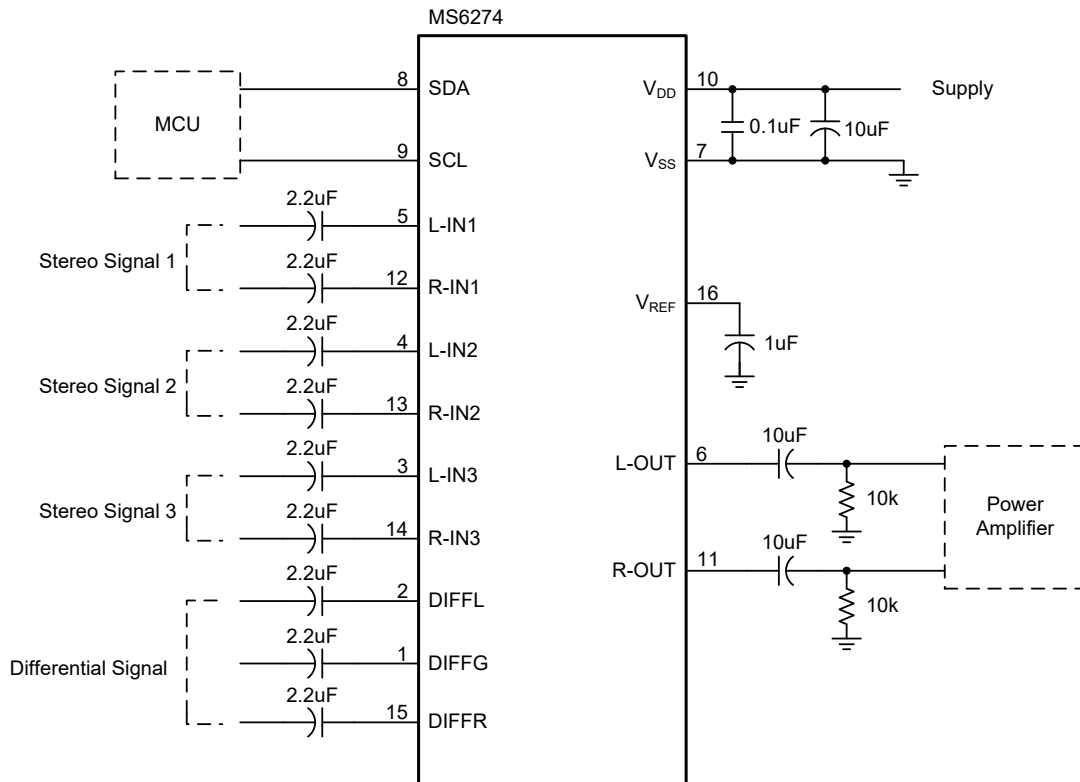

Basic application flowchart

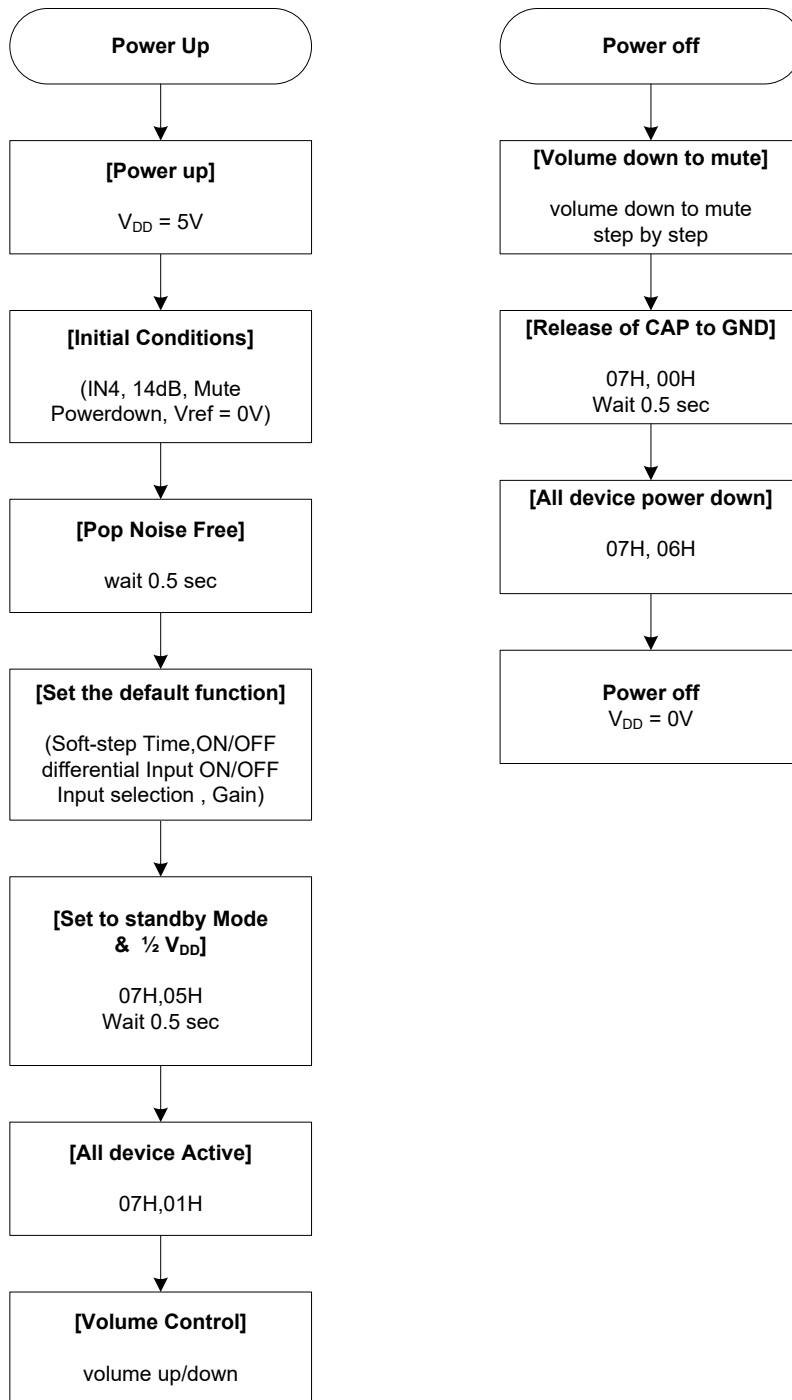

EXTERNAL DIMENSIONS

SSOP16

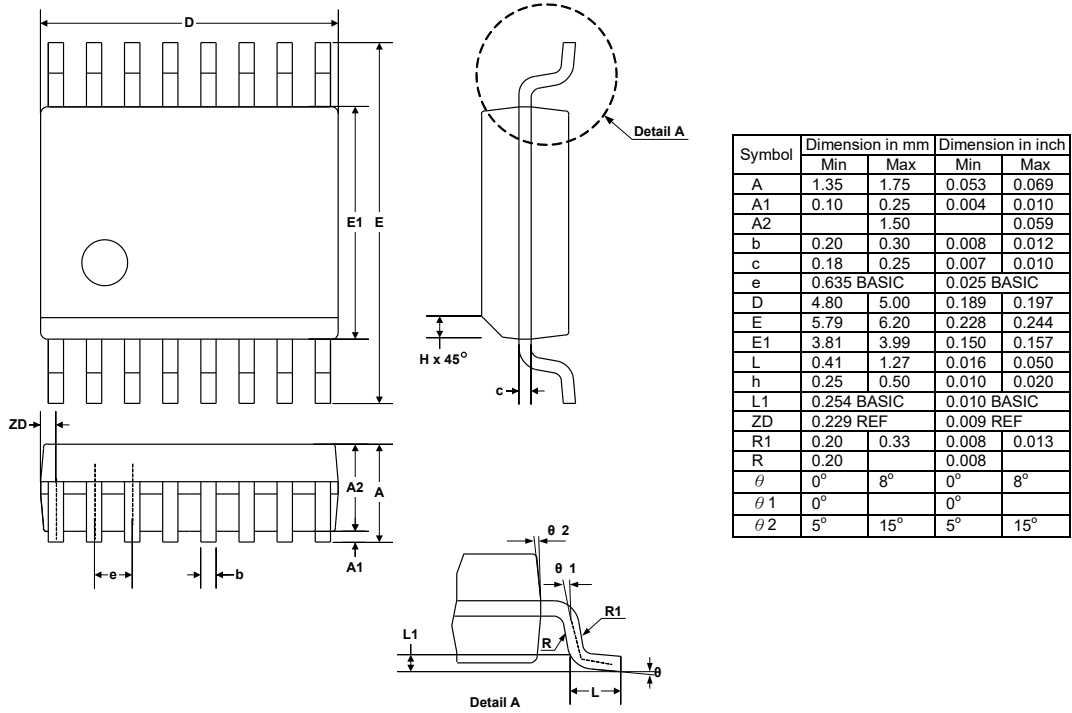

TAPE AND REEL (Unit : mm)

SSOP16

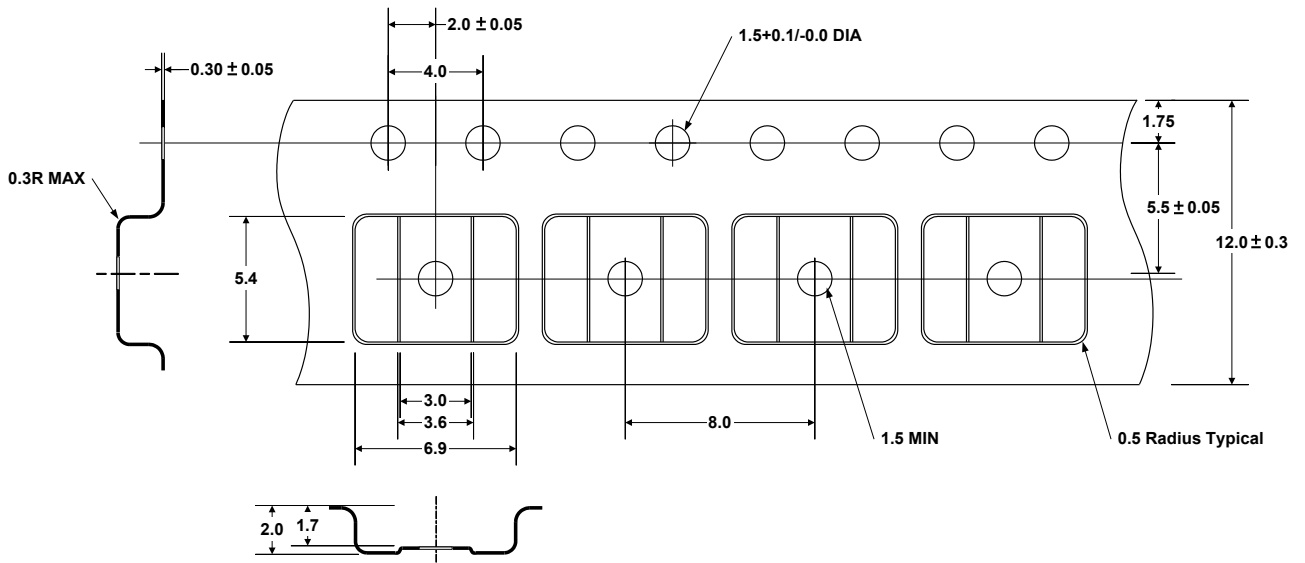

DEMO BOARD

The demo board used IR technique controller to control the MS6274. The default states of demo board are INPUT1, Input Gain 0dB, Volume 0dB, SE Mode, Softstep off, Mute off .

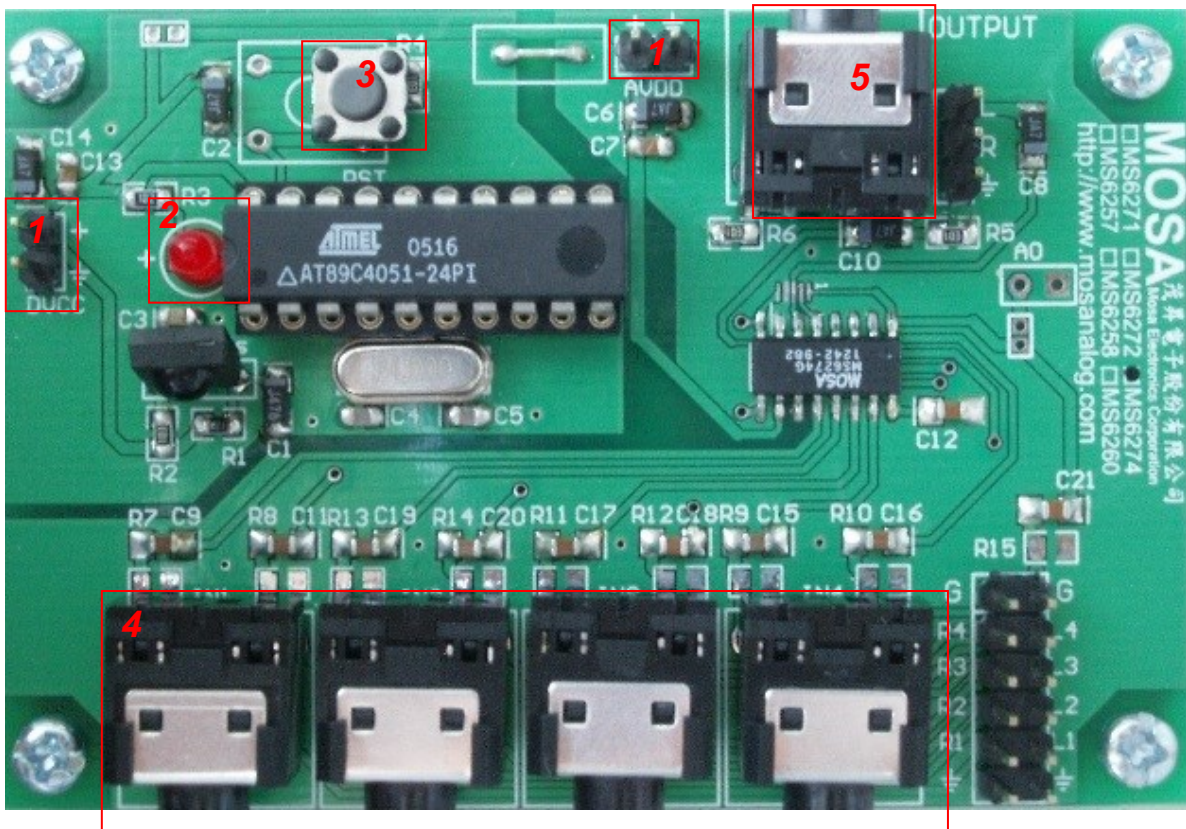

Label 1: Supply Voltage

The AVDD and DVDD should be the same supply voltage, the supply range is 2.5 ~ 6.5 VDC.

Label 2: LED Indicator

The LED indicates the power status and the IR received status. It is red-dark blink once when the MCU has received the function code correctly.

Label 3: MCU Reset

The MS6274 will be loaded the default values by MCU. The default states of demo board : INPUT1, Input Gain 0dB, Volume 0dB, SE Mode, Softstep off, Mute off.

Label 4: Input Section

Please input stereo audio signal, as music or sine wave.

Label 5: Output Section

Please connected to a post-power-amplifier, as active speaker.

IR Controller

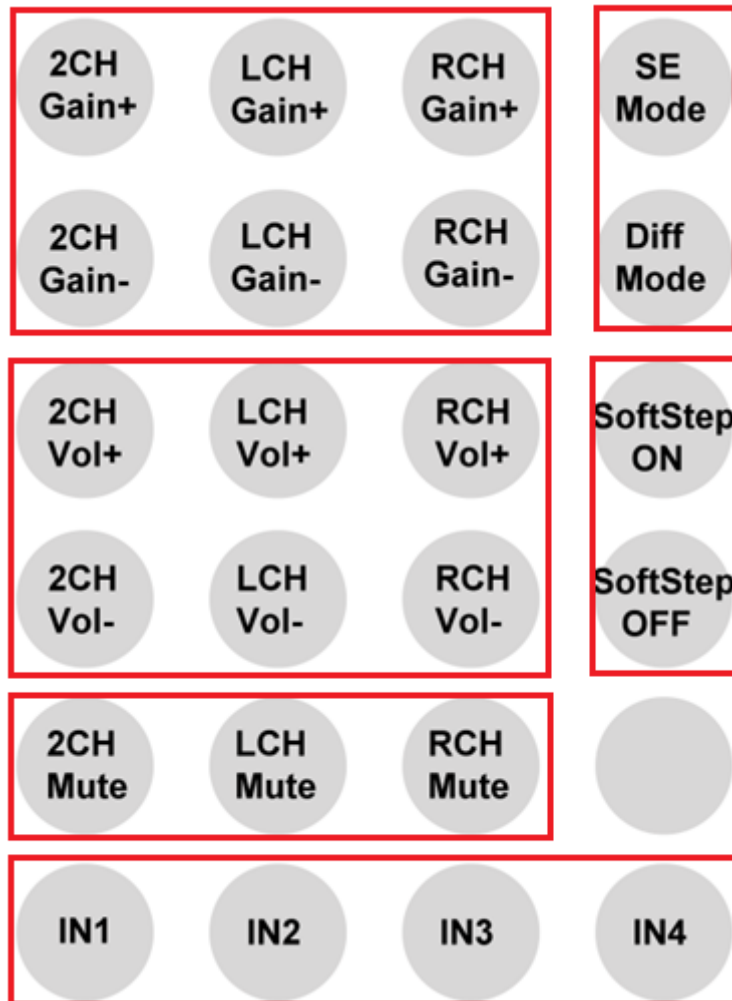

Gain+/- : The gain control keys.

The gain control in 1dB/step as the switch is pressed once, the range is 0dB to 15dB.

Vol+/- : The volume control keys.

The volume control in 1dB/step as the switch is pressed once, the range is -79dB to +15dB.

MUTE : The mute key controls all speaker outputs

Press the key once to set mute-on or mute-off.

SE/Diff Mode : The Input Mode control Keys.

SoftStep : The SoftStep key.

Press the key once to set Softstep on or SoftStep off.

IN1~IN4 : Stereo channel selection

There are four sets, stereo 1 to 4. The default channel is stereo 1 on initial status.

Circuit

