

16-Bits Stereo Audio DAC

Low Power Consumption

Low Voltage, Excellent PSRR

FEATURES

- Operation range: 2.5V~6.5V
- Excellent Power Supply Rejection Ratio(PSRR)
- Low operating current
- Low power consumption
8mW at $V_{DD}=3.3V$ (Full scale output)
- Low distortion
- No zero crossing distortion
- Wide dynamic range(16-bit resolution)
- Voltage Output
- Fast setting time permits 2*, 4*, and 8* oversampling (serial input) or double speed operation at 4* oversampling
- Compatible with most of the Japanese input formats; time multiplexed, two's complement, CMOS and TTL input level, MS6323AS for CMOS level, MS6323T for TTL level
- Output voltage swing is proportional to supply voltage ($V_{OPP}=V_{DD}/2$)
- Cost efficient
- Space saving package SOP8

APPLICATIONS

- Multimedia system
- MP3, PDA, Portable Digital Audio.

DESCRIPTION

The MS6323 is a 16-bit voltage-output Digital-to-Analog Converter(DAC). It gives the excellent Power Supply Rejection Ratio(PSRR). It features extremely low power dissipation, small package size and easy application. The accuracy of the weight current sources, combined with the unique symmetrical decoding method, preclude zero-crossing distortion and ensures high quality audio reproduction. These unique features, combined with its exceptional performance, make the MS6323 ideally suited for use in portable audio equipment. MS6323 is pin and function compatible with MS6313.

PIN CONFIGURATION

Symbol	Pin	Description
BCK	1	Bit clock input
WS	2	Word select input
DATA	3	Data input
GND	4	Ground
V_{DD}	5	Positive supply voltage
V_{OL}	6	Left channel output
Cap	7	Cap
V_{OR}	8	Right channel output

Pin 7 : Capacitor = 1 μ F (ripple rejection)

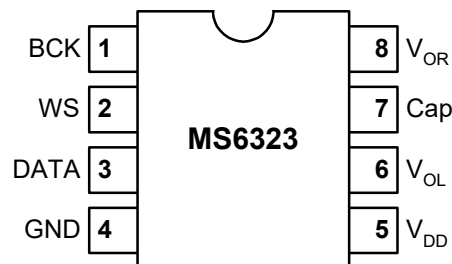

BLOCK DIAGRAM

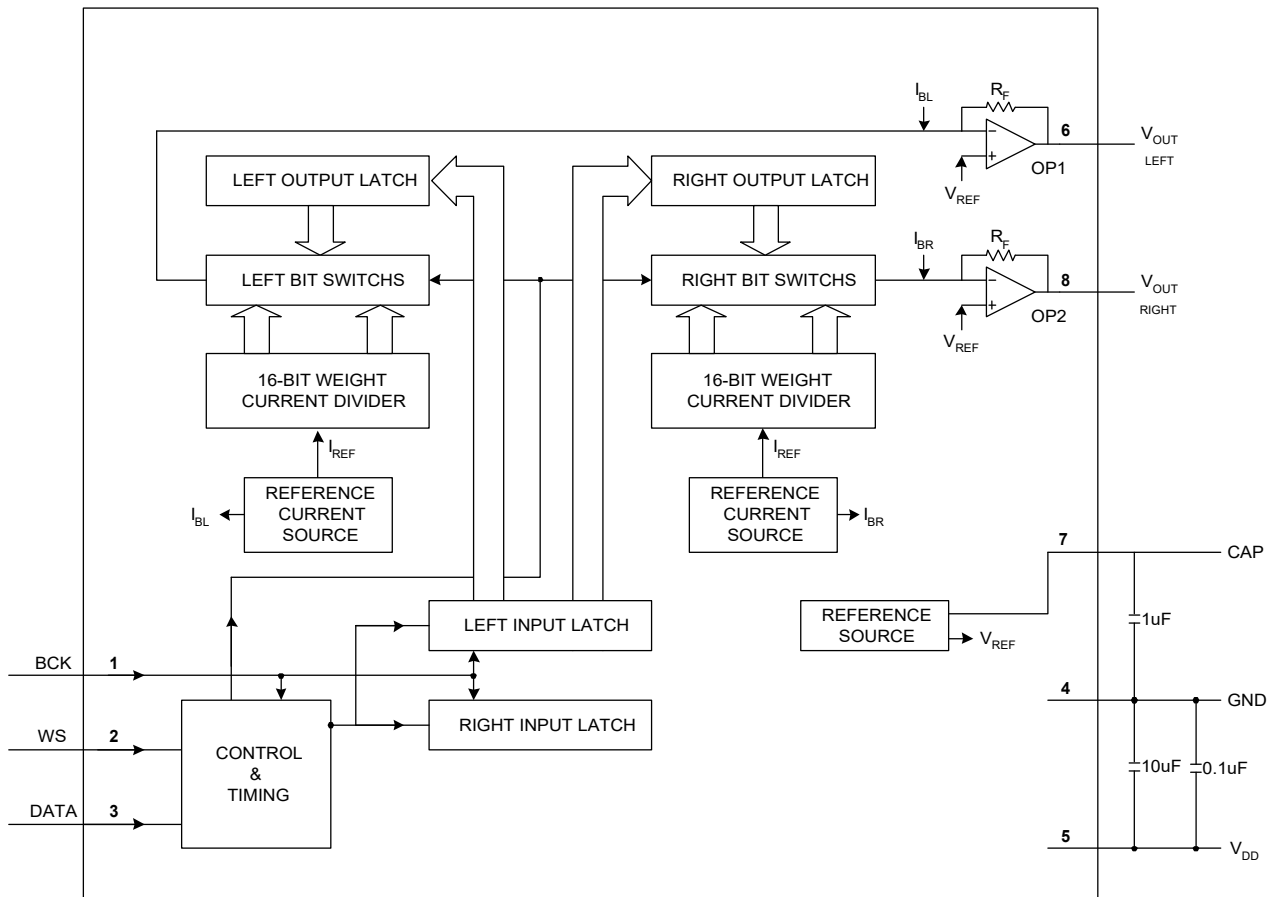

Fig.1 Block diagram.

ORDERING INFORMATION

CMOS input level

Package	Part number	Marking	Transport Media
8-Pin SOP (lead free)	MS6323ASGTR	MS6323ASG	2.5k Units Tape and Reel
8-Pin SOP (lead free)	MS6323ASGU	MS6323ASG	100 Units Tube

TTL input level

Package	Part number	Marking	Transport Media
8-Pin SOP (lead free)	MS6323TGTR	MS6323TG	2.5k Units Tape and Reel
8-Pin SOP (lead free)	MS6323TGU	MS6323TG	100 Units Tube

RoHS Compliance

ABSOLUTE MAXIMUM RATINGS

Symbol	Parameter	Rating	Unit
V _{DD}	Positive Supply Voltage	6.5	V
V _{ESD}	Electrostatic Handling	-2000 to 2000	V
T _{STG}	Storage Temperature Range	-65 to 150	°C
T _A	Operating Ambient Temperature Range	-40 to 85	°C
T _J	Maximum Junction Temperature	150	°C
T _S	Soldering Temperature, 10 seconds	260	°C
R _{THJA}	Thermal Resistance from Junction to Ambient in Free Air SOP8	210	°C/W

OPERATING RATINGS

Symbol	Parameter	Min	Typ	Max	Unit
V _{DD}	Supply Voltage	2.5	-	6.5	V

5V ELECTRICAL CHARACTERISTICS

(T_a=25°C, V_{DD}=5V, f=1kHz, Cap=1uF; unless otherwise specified)

Symbol	Parameter	Conditions	Min	Typ	Max	Unit
DC Characteristics						
V _{CAP}	Voltage at Cap		2.45	2.5	2.55	V
V _{DC}	Output DC level		2.45	2.5	2.55	V
V _{FS}	Full scale output voltage	V _{FS} =0.5V _{DD}	2.3	2.5	2.7	V _{pp}
I _Q	Quiescent current	At code 0000H	-	2.6	-	mA
I _{FS}	Maximum operation current	V _{FS} =0.5V _{DD}	-	3.8	-	mA
PSRR	Power supply rejection ratio	Cap=1uF, f=100Hz	44	49	-	dB
		Cap=10uF, f=100Hz	60	65	-	dB
CS	Channel separation		81	87	-	dB
AC Characteristics						
Res	Resolution		-	-	16	bits
THD+N	Total harmonic distortion plus noise		-	-68	-64	dB
			-	0.04	0.063	%
S/N	Signal-to-noise ratio		89	95	-	dB

3.3V ELECTRICAL CHARACTERISTICS

($T_a=25^{\circ}\text{C}$, $V_{DD}=3.3\text{V}$, $f=1\text{kHz}$, $\text{Cap}=1\mu\text{F}$; unless otherwise specified)

Symbol	Parameter	Conditions	Min	Typ	Max	Unit
DC Characteristics						
V_{CAP}	Voltage at CAP		1.6	1.65	1.7	V
V_{DC}	Output DC level		1.6	1.65	1.7	V
V_{FS}	Full scale output voltage	$V_{FS}=0.5V_{DD}$	1.5	1.65	1.8	V _{pp}
I_Q	Quiescent current	At code 0000H	-	2.2	-	mA
I_{FS}	Maximum operation current	$V_{FS}=0.5V_{DD}$	-	2.3	-	mA
PSRR	Power supply rejection ratio	Cap=1uF, f=100Hz	45	50	-	dB
		Cap=10uF, f=100Hz	63	68	-	dB
CS	Channel separation		78	84	-	dB
AC Characteristics						
THD+N	Total harmonic distortion plus noise		-	-66	-62	dB
			-	0.05	0.08	%
S/N	Signal-to-noise ratio		86	92	-	dB

2.5V ELECTRICAL CHARACTERISTICS

($T_a=25^{\circ}\text{C}$, $V_{DD}=2.5\text{V}$, $f=1\text{kHz}$, $\text{Cap}=1\mu\text{F}$; unless otherwise specified)

Symbol	Parameter	Conditions	Min	Typ	Max	Unit
DC Characteristics						
V_{CAP}	Voltage at CAP		1.2	1.25	1.3	V
V_{DC}	Output DC level		1.2	1.25	1.3	V
V_{FS}	Full scale output voltage	$V_{FS}=0.5V_{DD}$	1.2	1.25	1.5	V _{pp}
I_Q	Quiescent current	At code 0000H	-	2.0	-	mA
I_{FS}	Maximum operation current	$V_{FS}=0.5V_{DD}$	-	2.1	-	mA
PSRR	Power supply rejection ratio	Cap=1uF, f=100Hz	44	49	-	dB
		Cap=10uF, f=100Hz	59	64	-	dB
CS	Channel separation		77	83	-	dB
AC Characteristics						
THD+N	Total harmonic distortion plus noise		-	-66	-62	dB
			-	0.05	0.08	%
S/N	Signal-to-noise ratio		83	89	-	dB

TYPICAL PERFORMANCE CHARACTERISTICS

($T_a=25^\circ\text{C}$, $f=1\text{kHz}$, $\text{Cap}=1\mu\text{F}$, $\text{sampling rate}=4\text{fs}$; unless otherwise specified,)

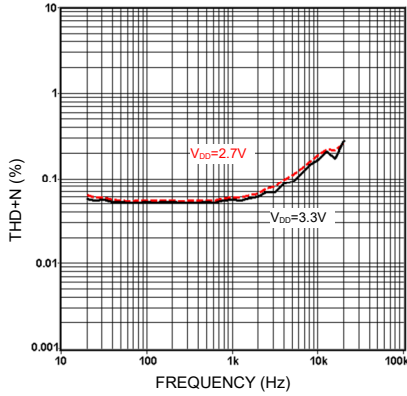

THD+N vs. frequency

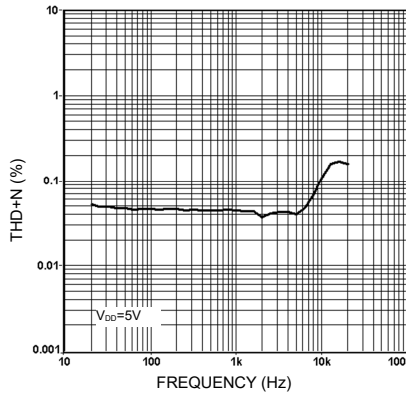

THD+N vs. frequency

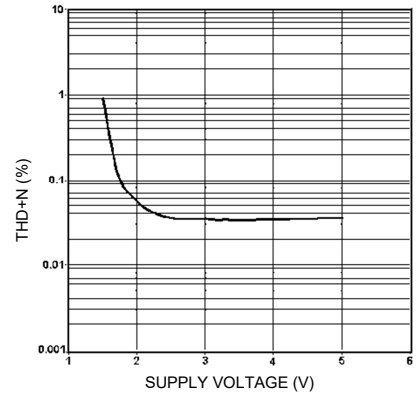

THD+N vs. supply voltage

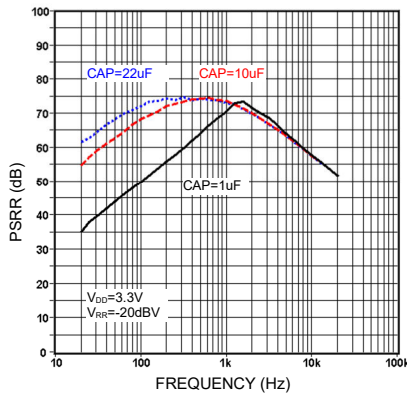

PSRR vs. frequency

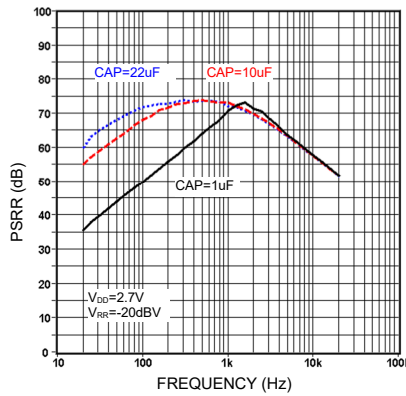

PSRR vs. frequency

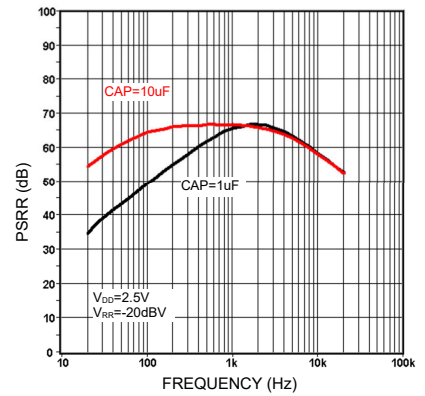

PSRR vs. frequency

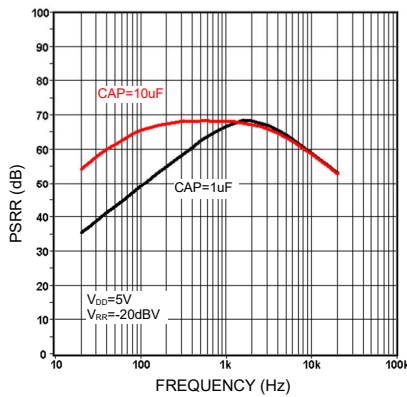

PSRR vs. frequency

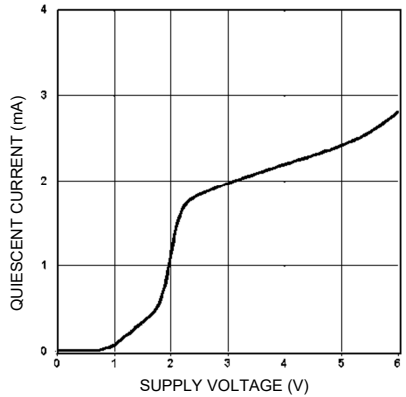

Quiescent current vs. supply voltage

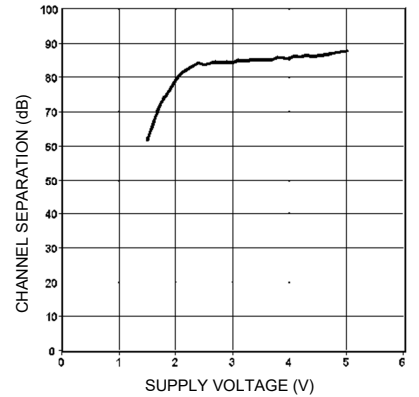

Channel separation vs. supply voltage

TIMING AND DATA FORMAT

The MS6323 accepts input serial data formats of 16-bit word length. Left and right data words are time multiplexed. The MSB must always be first. The format of data input is shown in Figs. 2 and 3. With a HIGH level on the word select input (WS), data is placed in the left input register and with LOW level on the WS input, data is placed in the right register (Fig. 1). The data in the input registers are simultaneously latched in the output registers which control the bit switches. Internal bias currents I_{BL} and I_{BR} are each added to the full scale output current I_{FS} in order to achieve the maximum dynamic range at the outputs of OP1 and OP2(Fig. 1). In this way the maximum dynamic range is achieved over the entire power supply range.

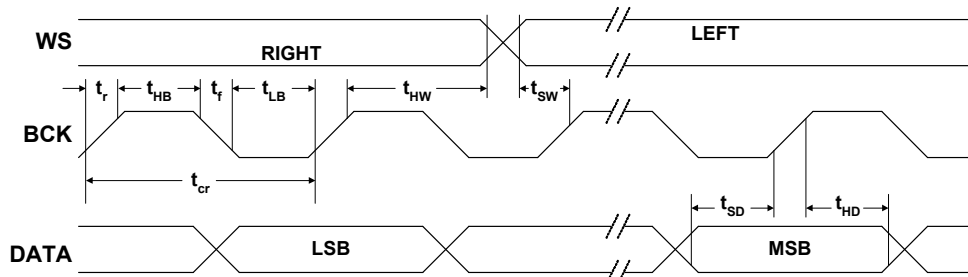

Fig.2 Timing and input signals.

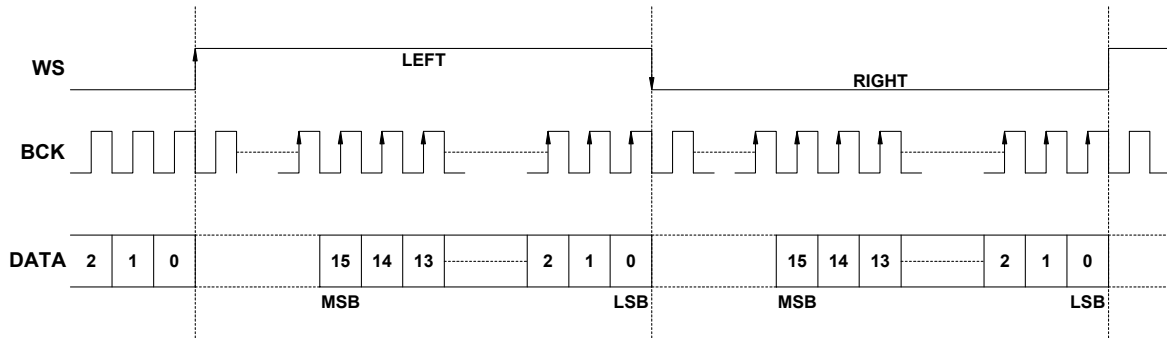

Fig.3 Format of input signals.

Data format (BCK, WS, DATA)

Symbol	Parameter	Conditions	Min	Typ	Max	Unit
V _{IL}	Input LOW CMOS level	MS6323AS	-	-	0.3V _{DD}	V
	Input LOW TTL level	MS6323T	-	-	0.8	V
V _{IH}	Input HIGH CMOS level	MS6323AS	0.7V _{DD}	-	-	V
	Input HIGH TTL level	MS6323T	2	-	-	V
I _{IL}	Input Leakage Current LOW		-	-	10	μA
I _{IH}	Input Leakage Current HIGH		-	-	10	μA
f _{BCK}	Input Clock Frequency		-	-	18.4	MHz
BR	Bit Rate Data Input		-	-	18.4	Mbits/s
f _{WS}	Word Select Input		-	-	384	kHz
t _r	Rise Time		-	-	12	ns
t _f	Fall Time		-	-	12	ns
t _{cr}	Bit Clock Cycle Time		54	-	-	ns
t _{HB}	Bit Clock High Time		15	-	-	ns
t _{LB}	Bit Clock Low Time		15	-	-	ns
t _{SD}	Data Set-up Time		12	-	-	ns
t _{HD}	Data Hold Time to Bit Clock		2	-	-	ns
t _{HW}	Word Select Hold Time		2	-	-	ns
t _{SW}	Word Select Set-up Time		12	-	-	ns

APPLICATION INFORMATION

MP3 digital to analog converting solution

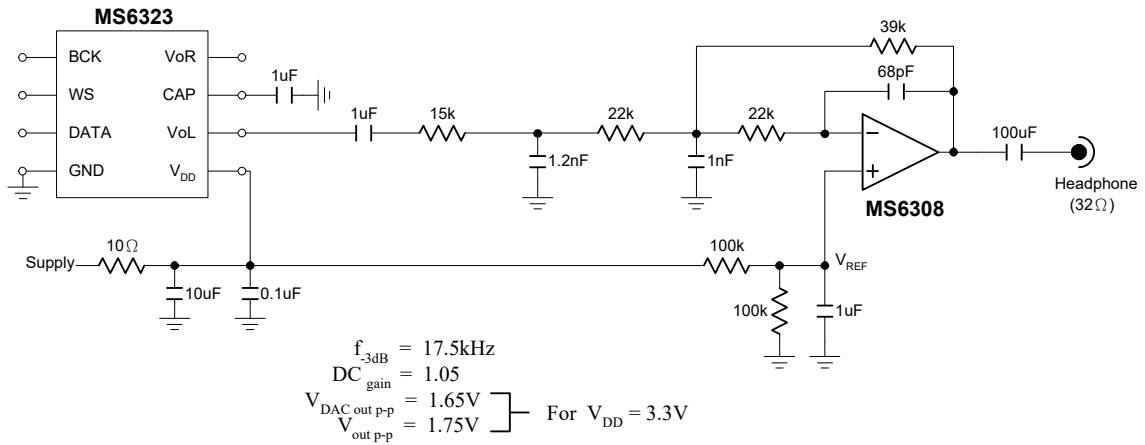

Fig.4 A third order lowpass filter (Smoothing filter) for DAC output.

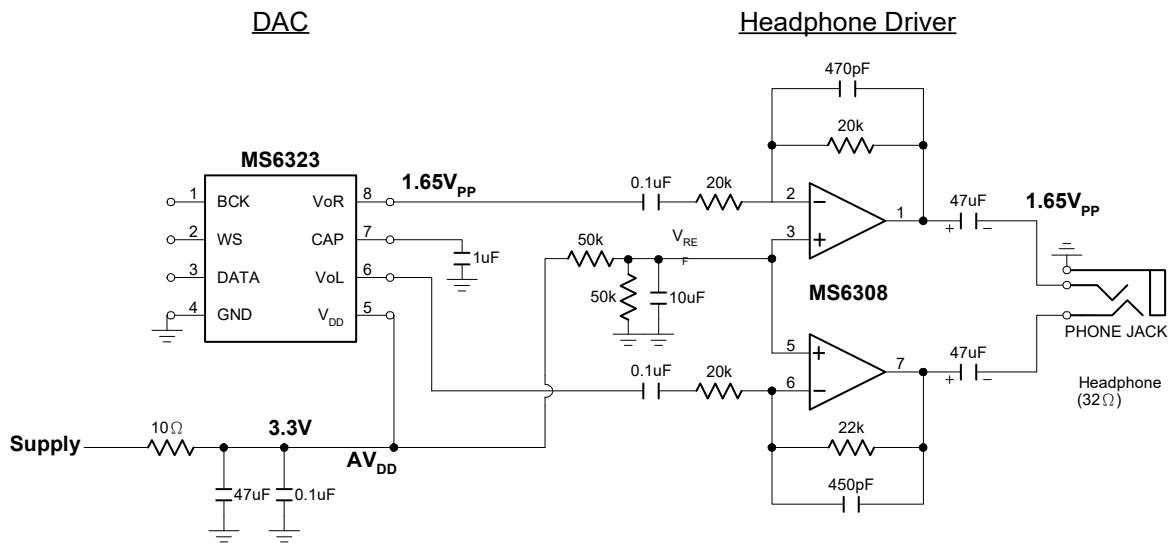
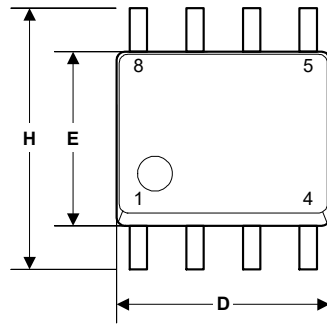
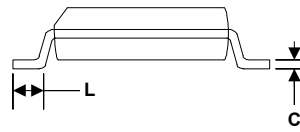
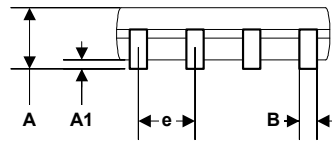

Fig.5 A first order lowpass filter for DAC output.

EXTERNAL DIMENSIONS



Symbol	Dimension in mm		Dimension in inch	
	Min	Max	Min	Max
A	1.35	1.75	0.0532	0.0688
A1	0.10	0.25	0.0040	0.0098
B	0.33	0.51	0.013	0.020
C	0.19	0.25	0.0075	0.0098
D	4.80	5.00	0.1890	0.1968
H	5.80	6.20	0.2284	0.2440
E	3.80	4.00	0.1497	0.1574
e	1.27 BSC		0.050 BSC	
L	0.40	1.27	0.016	0.050



SOP8

TAPE AND REEL (Unit : mm)

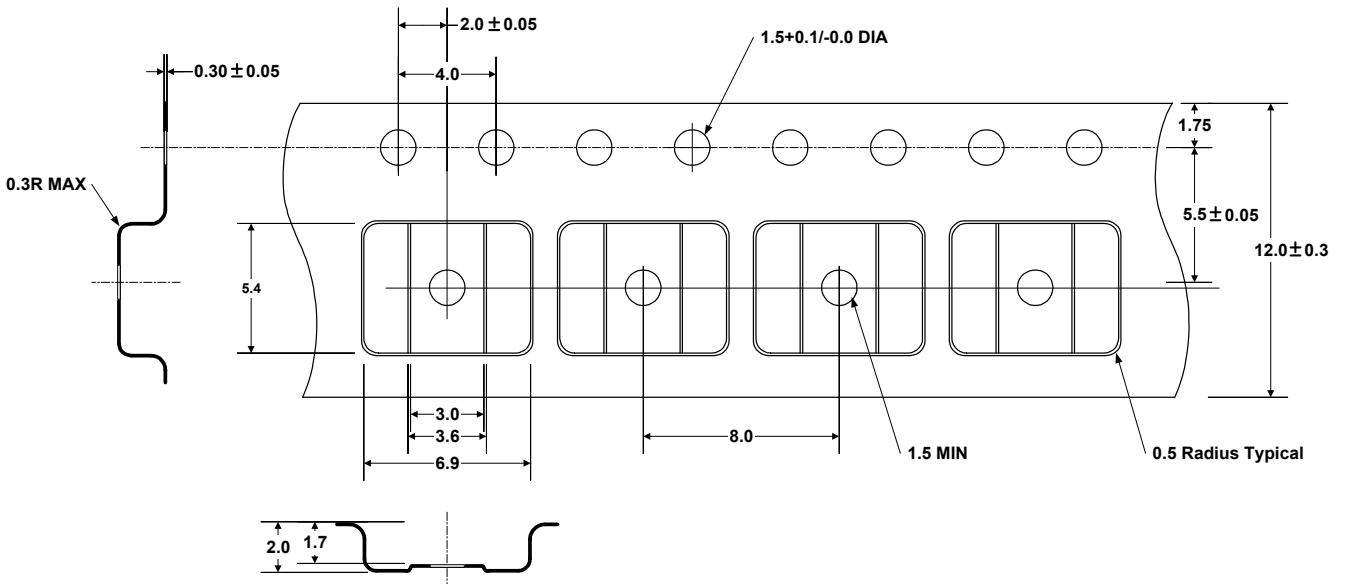

SOP8

Demo board

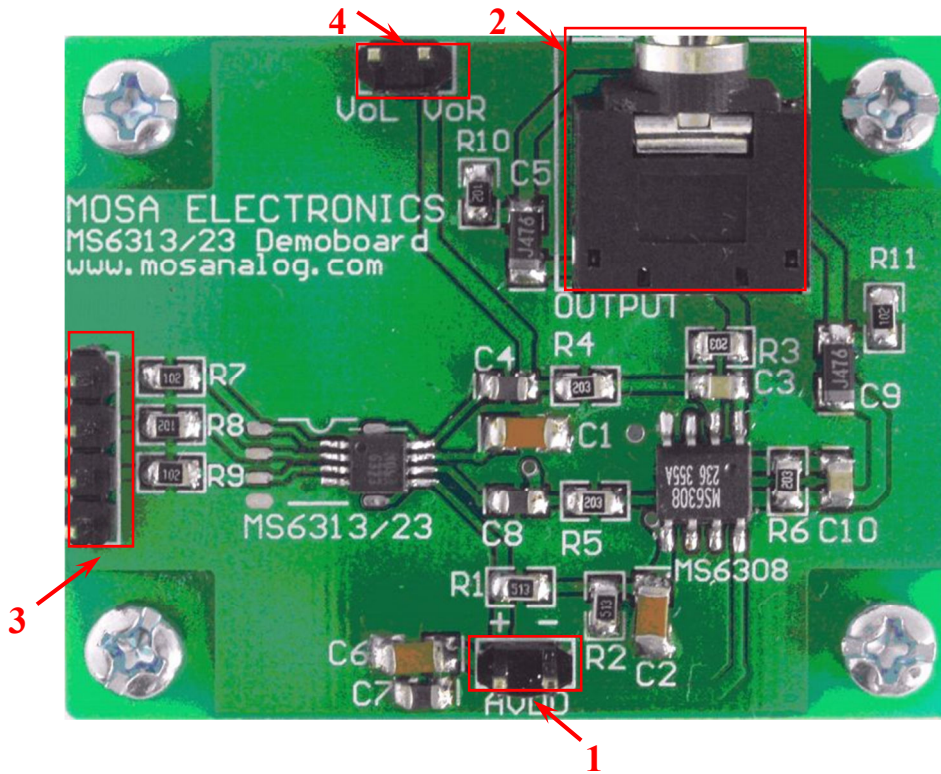

Function description

Label 1: Supply Input
Supply voltage range is 2.5V to 6.5V.

Label 2: Headphone Jack
Used 3.5mm diameter of headphone with 32ohm.

Label 3: Digital Signal Input
Connected to digital audio format.

Label 4: MS6323 output
MS6323 output test ports.

Circuit

