

4.1聲道音頻處理器具SoftStep功能音量控制與重低音

4.1Channel audio processor with Volume soft steps and Subwoofer

特性(FEATURES)

- 工作電壓(Operation range) : 3.3V~5V
- 4組立體聲輸入含一組差動輸入
(4 Stereo inputs, 1 quasi-differential input)
- Soft-step音量控制 (Soft-step volume)
- 高低音與響度控制(Bass, treble and loudness)
- 4個獨立揚聲器輸出(4 independent speaker outputs)
- 1組重低音輸出(Subwoofer output)
- I²C 控制介面(I²C interface)
- 精簡的外部元件與優異的PSRR
(Components less and good PSRR)

應用(APPLICATIONS)

- 可攜式裝置(Portable audio device)
- 汽車音響(Car stereo audio)
- Housed in SSOP36 package

功能描述(DESCRIPTION)

MS6741是專為汽車音響設計之4.1聲道音質處理器。使用I2C介面控制所有功能。具4組立體聲音源輸入，可調增益，主音量控制，高低音控制，且皆具有Soft-step功能，能有效抑制音量控制時音量瞬間改變造成的爆音。
(The MS6741 is a 4.1CH audio processor designed for car audio and Hi-Fi audio systems. Using I2C interface controls all of the functions. Like most of audio processors, it equips up to 4 stereo sources input with adjustable gain, master volume with adaptive loudness, treble and bass control.)

在汽車音響，因為需要前座與後座獨立控制，因此MS6741提供單獨的輸入音源選擇器與輸出音量。另有額外的混和放大器，可供導航系統或行動電話相結合。

(In a car entertainment system where needs front and rear seat individual control, the MS6741 provides separate input source selection and output volume adjustment; a special design, mixing amp, is very easy to combine the navigation system or cellular phone's voice with the car audio system.)

方塊圖(BLOCK DIAGRAM)

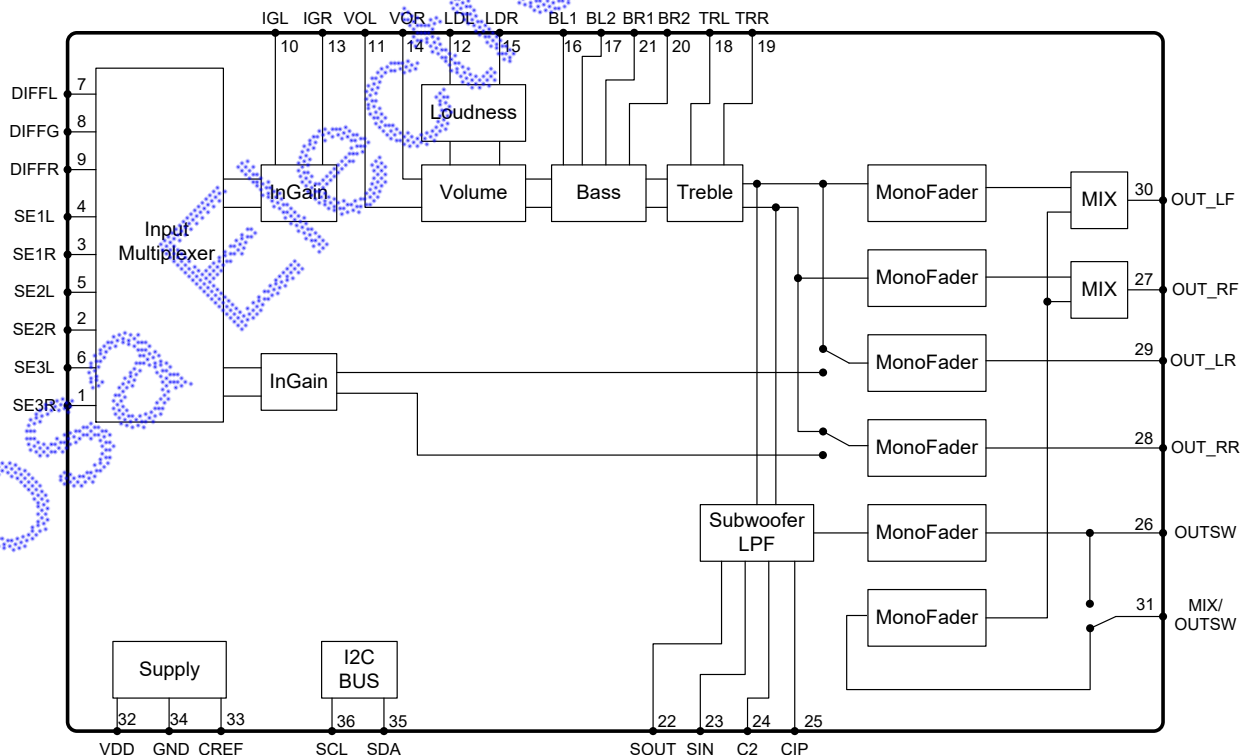

腳位配置 (PIN CONFIGURATION)

符號 Symbol	腳位 Pin	描述 Description
SE3R	1	3 rd Right Channel Input
SE2R	2	2 nd Right Channel Input
SE1R	3	1 st Right Channel Input
SE1L	4	1 st Left Channel Input
SE2L	5	2 nd Left Channel Input
SE3L	6	3 rd Left Channel Input
DIFFL	7	Left Differential Input / 4 th Left Channel Input
DIFFG	8	Differential Input Common / N.C.
DIFFR	9	Right Differential Input / 4 th Right Channel Input
IGL	10	Left Channel Input Selector Output
VOL	11	Left Channel Volume Input
LDL	12	Left Channel Loudness Input
IGR	13	Right Channel Input Selector Output
VOR	14	Right Channel Volume Input
LDR	15	Right Channel Loudness Input
BL1	16	Left Channel Bass Cap 1
BL2	17	Left Channel Bass Cap 2
TRL	18	Left Channel Treble Cap
TRR	19	Right Channel Treble Cap
BR2	20	Right Channel Bass Cap 2
BR1	21	Right Channel Bass Cap 1
SOUT	22	L+R Output(-6dB Gain)
SIN	23	Subwoofer Filter Input
C2	24	Subwoofer Filter Cap2
C1P	25	Subwoofer Filter Cap1
OUTSW	26	Subwoofer Output
OUTRF	27	Right Front Output
OUTRR	28	Right Rear Output
OUTLR	29	Left Rear Output
OUTLF	30	Left Front Output
MIX/OUTSW	31	Mix Input / Subwoofer Output
VDD	32	Positive Supply Voltage
CREF	33	Reference Voltage = 1/2V _{DD}
GND	34	Ground
SDA	35	I ² C Data Input
SCL	36	I ² C Clock Input

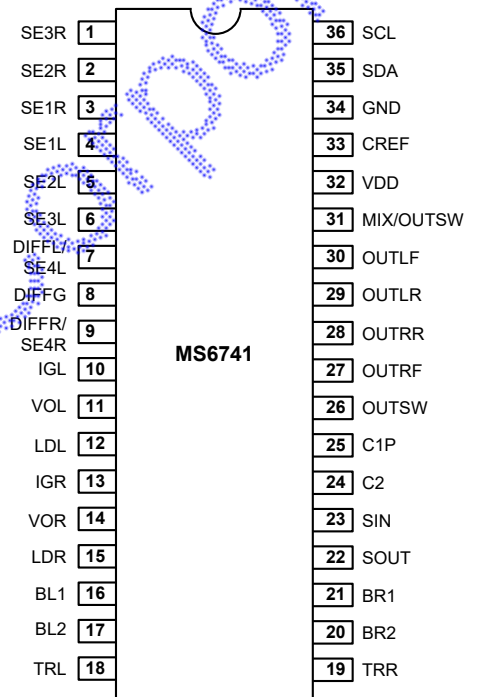

訂購資訊(ORDERING INFORMATION)

封裝型式 Package	產品編號 Part number	封裝正印 Packaging Marking	運輸包裝 Transport Media
36-Pin SSOP (lead free)	MS6741SSTR	MS6741G	1K Units Tape and Reel
36-Pin SSOP (lead free)	MS6741SSU	MS6741G	30 Units Tube

RoHS Compliance

最大容許規格(ABSOLUTE MAXIMUM RATINGS)

符號 Symbol	參數 Parameter	額定值 Rating	單位 Unit
V _{DD}	工作電壓(Supply Voltage)	6.5	V
V _{ESD}	抗靜電處理(Electrostatic Handling)	-2000 to 2000	V
T _{STG}	儲存溫度(Storage Temperature Range)	-65 to 150	°C
T _A	工作環境溫度(Operating Ambient Temperature Range)	-40 to 85	°C
T _J	最大接合溫度(Maximum Junction Temperature)	150	°C
T _S	焊接溫度, 10秒(Soldering Temperature, 10 seconds)	260	°C
R _{THJA}	接面熱阻(空氣) Thermal Resistance from Junction to Ambient in Free Air SSOP36	210	°C/W

電氣特性(ELECTRICAL CHARACTERISTICS)

(Ta=25°C, V_{DD} =5V, All stages 0dB, f=1kHz, C_{REF} =10uF, refer to the application circuit; unless otherwise specified)

符號 Symbol	參數 Parameter	測試條件 Conditions	最小值 Min	額定值 Typ	最大值 Max	單位 Unit
電源供應(Supply)						
I _Q	靜態電流 Quiescent Current	V _{IN} =0V	-	18	-	mA
PSRR	電源漣波拒斥比 Power Supply Rejection Ratio	C _{REF} = 10uF, f= 100Hz	-	60	-	dB
輸入選擇(Input Selector)						
R _{IN}	輸入阻抗 Input Resistance	SE/Diff	40	60	80	kΩ
G _{IN}	輸入增益範圍 Input Gain Range	Gain	0	-	+15	dB
G _{STEP}	解析度 Step Resolution		-1	1	+1	dB
ERR _G	誤差範圍 Gain Setting error		-0.5	0	+0.5	dB
CMRR	共模拒斥比 Common Mode Rejection Ratio	V _{cm} = 1Vrms@1K	-	60	-	dB
R _L	最大負載 Minimum Load	IGL, IGR	-	10	-	kΩ
音量控制(Volume control)						
R _{IN}	輸入阻抗 Input resistance	Loud = ON	60	80	100	kΩ
		Loud = OFF	15	25	40	
CR _{GAIN}	輸入增益範圍 Gain Range		0	-	+15	dB
RES _{GAIN}	增益解析度 Gain Step Resolution		-	1	-	dB
CR _{VOL}	音量控制範圍 Volume Control Range	Attenuation	-79	-	0	dB
RES _{VOL}	音量控制解析度 Volume Step Resolution		-	1	-	dB
ERR _{VOL}	音量控制誤差 Volume Setting Error	Av = -40 to +15dB	-0.5	0	1	dB
		Av = -79 to -41dB	-1	0	5	dB
Mute	靜音 Mute Attenuation		-	90	-	dB
響度控制(Loudness Control)						
CR _{Loud}	響度控制範圍 Loudness Control Range		-15	-	0	dB
RES _{Loud}	響度控制解析度 Loudness Step Resolution		-	1	-	dB
ERR _{Loud}	響度控制誤差 Loudness Setting Error	f =20kHz	-1	0	1	dB
低音控制(Bass Control)						
CR _{BAS}	低音控制範圍 Bass Control Range	Gain/attenuation	-15	0	+15	dB
RES _{BAS}	低音控制解析度 Bass Step Resolution		-	1	-	dB
ERR _{BAS}	低音控制誤差 Bass Setting Error	f =100Hz	1	0	1	dB

高音控制(Treble Control)						
CR _{TRE}	高音控制範圍 Treble Control Range	Boost/Cut	-15	0	+15	dB
RES _{TRE}	高音控制解析度 Treble Step Resolution		-	1	-	dB
ERR _{TRE}	高音控制誤差 Treble Setting Error	f = 20kHz	-1	0	1	dB
重低音控制(Subwoofer Output Control)						
CR _{GAIN}	增益範圍 Gain Range	Front and Rear Channels	0	-	+15	dB
RES _{GAIN}	增益解析度 Gain Step Resolution		-	1	-	dB
CR _{VOL}	音量控制範圍 Volume Control Range	Attenuation	-79	-	0	dB
RES _{VOL}	音量控制解析度 Volume Step Resolution		-	1	-	dB
ERR _{VOL}	音量控制誤差 Volume Setting Error	Av = -40 to +15dB	-0.5	0	1	dB
		Av = -79 to -41dB	-1	0	5	dB
Mute	靜音 Mute Attenuation		-	90	-	dB
F _{LP}	F _{LP1}	Lowpass corner frequency	-	80	-	Hz
	F _{LP2}		-	120	-	Hz
	F _{LP3}		-	160	-	Hz
揚聲器衰減(Speaker Attenuators)						
CR _{GAIN}	增益範圍 Gain Range	Front and Rear Channels	0	-	+15	dB
RES _{GAIN}	增益解析度 Gain Step Resolution		0.5	1	1.5	dB
CR _{VOL}	音量控制範圍 Volume Control Range	Attenuation	-79	-	0	dB
RES _{VOL}	音量控制解析度 Volume Step Resolution		-	1	-	dB
ERR _{VOL}	音量控制誤差 Volume Setting Error	Av = 0 to -40dB	-0.5	0	0.5	dB
		Av = -40 to -60dB	-5	0	5	dB
Mute	Mute Attenuation		-	80	-	dB
混合控制(Mixing control)						
CR _{GAIN}	增益範圍 Gain Range		0	-	+15	dB
RES _{GAIN}	增益解析度 Gain Step Resolution		-	1	-	dB
CR _{VOL}	音量控制範圍 Volume Control Range	Attenuation	-79	-	0	dB
RES _{VOL}	音量控制解析度 Volume Step Resolution		-	1	-	dB
Mlevel	Mixing Ratio	Main & Mix-In Source	-	-6	-	dB

一般(General)						
V _O MAX	最大輸出電壓振幅 Maximum Output Voltage Swing	(THD+N)/S <0.3%	-	1.5	-	Vrms
THD+N	總諧波失真 Total Harmonic Distortion Plus Noise	V _{OUT} =2Vpp	-	85	-	dB
			-	0.005	-	%
S/N	訊號雜訊比 Signal-to-Noise Ratio	V _{OUT} =4Vpp	-	90	-	dB
CS	聲道隔離度 Channel Separation		-	80	-	dB
I ² C匯流排輸入(Bus Input)						
V _{IH}	輸入高準位 Bus High Input Level		2	-	-	V
V _{IL}	輸入低準位 Bus Low Input Level		-	-	0.8	V

典型的特性曲線圖 (TYPICAL PERFORMANCE CHARACTERISTICS)

($T_a=25^\circ\text{C}$, $V_{DD}=5\text{V}$, All stages 0dB, $f=1\text{kHz}$, $C_{REF}=10\mu\text{F}$, refer to the application circuit; unless otherwise specified)

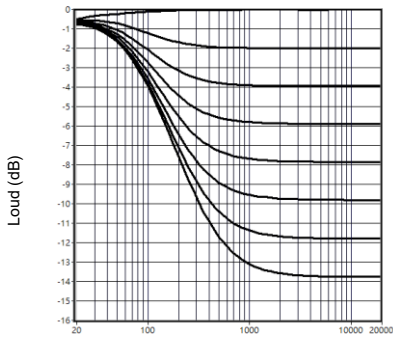

FREQUENCY (Hz)
Loudness vs. Volume

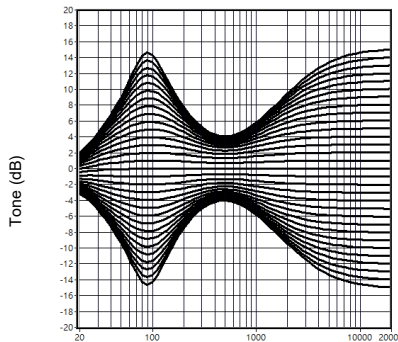

FREQUENCY (Hz)
Typical Tone Response

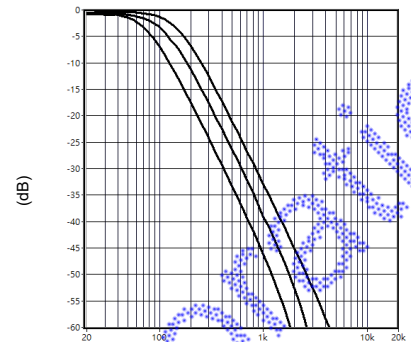

FREQUENCY (Hz)
Lowpass corner frequency

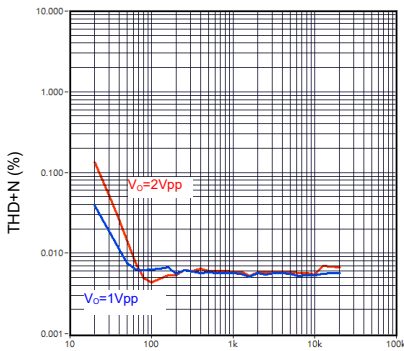

FREQUENCY (Hz)
THD+N vs. Frequency

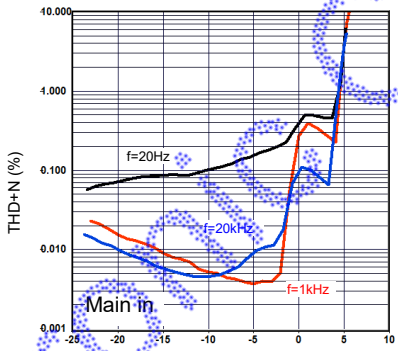

OUTPUT VOLTAGE (dBV)
THD+N vs. Output Voltage

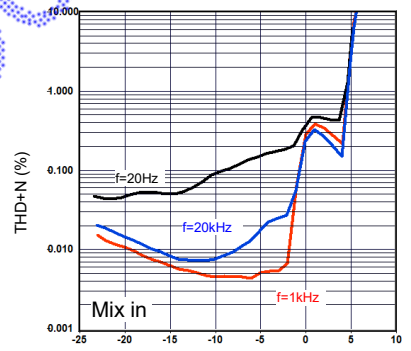

OUTPUT VOLTAGE (dBV)
THD+N vs. Output Voltage

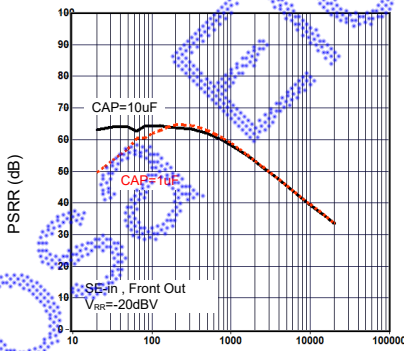

FREQUENCY (Hz)
PSRR vs. Frequency

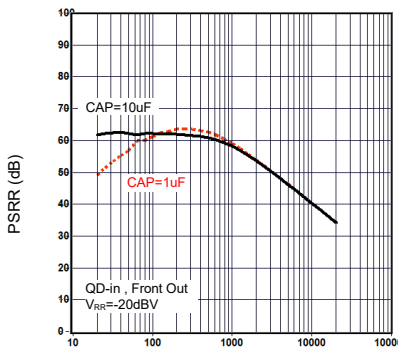

FREQUENCY (Hz)
PSRR vs. Frequency

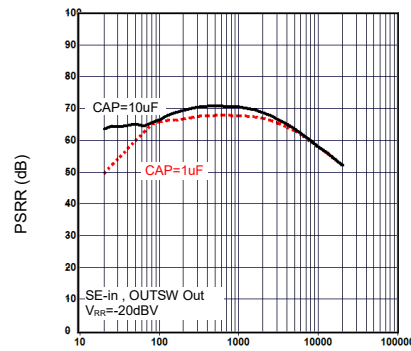

FREQUENCY (Hz)
PSRR vs. Frequency

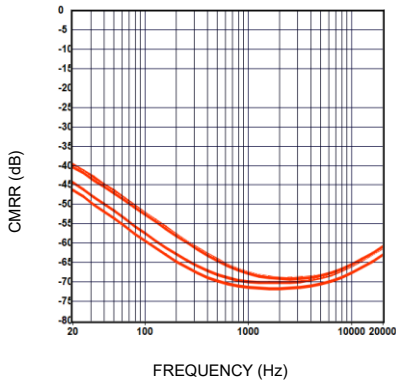

CMRR

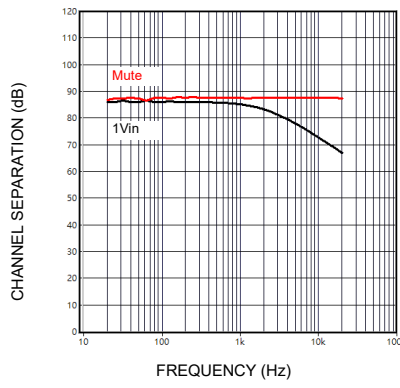

Channel Separation vs. Frequency

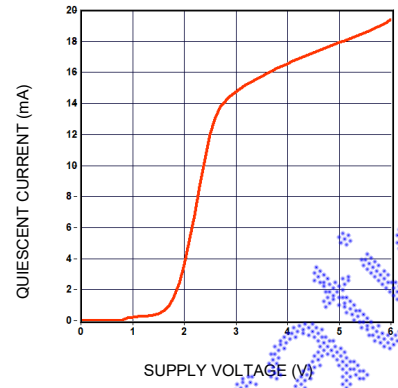

Quiescent Current vs. Supply Voltage

Mosa Electronic Corporation

I²C 匯流排描述 (I²C BUS DESCRIPTION)

開始與結束條件 (Start and Stop Conditions)

當SCL設定在高準位且SDA由“高準位”轉變為“低準位”時；則表示序列“開始”，而當SCL在高準位且SDA由低準位上升到高準位時；則序列結束。請參考下列時序圖。

A start condition is activated when the SCL is set to HIGH and SDA shifts from HIGH to LOW state. The stop condition is activated when SCL is set to HIGH and SDA shifts from LOW to HIGH state. Please refer to the timing diagram below.

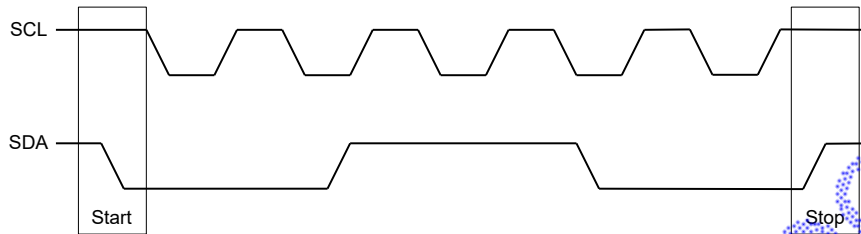

SCL：串列時序輸入線 (Serial Clock Line), SDA：串列資料輸入線 (Serial Data Line)

資料確認 (Data Validity)

當CLK (SCL) 訊號在“高準位”時，資料線 (SDA) 上的資料才會被視為正確且穩定的資料。而只有當CLK訊號在“低準位”時，資料線才可做高、低準位的切換。請參閱下圖：

A data on the SDA line is considered valid and stable only when the SCL signal is in HIGH state. The HIGH and LOW states of the SDA line can only change when the SCL signal is LOW. Please refer to the figure below.

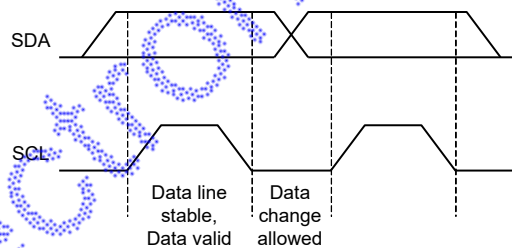

位元組格式 (Byte Format)

每一個傳輸到資料線的位元組(byte)有八個位元(bit)，每一位元組後面需有一“認可”位元，且以最大符號位元 (MSB) 為首的方式傳送出去。

Every byte transmitted to the SDA line consists of 8 bits. Each byte must be followed by an acknowledge bit.

The MSB is transmitted first.

認可信號 (Acknowledge)

在第九個時脈時主體(微處理機)先將SDA設定為電阻性的高準位，若週邊設備(MS6741)認可此信號，則SDA將會被週邊設備拉至低準位，使SDA在此時脈中保持一穩定的低準位狀態。請參閱下圖：

During the Acknowledge clock pulse, the master (up) put a resistive HIGH level on the SDA line. The peripheral (audio processor) that acknowledges has to pull-down (LOW) the SDA line during the Acknowledge clock pulse so that the SDA line is in a stable LOW state during this clock pulse. Please refer to the diagram below.

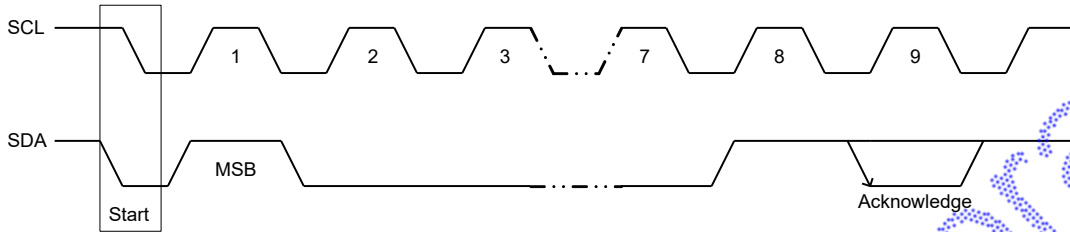

這個已被定址的設備在收到每一位元組(BYTE)後，即產生一“認可”的動作；否則在第九個時脈(CLOCK)的時間內SDA將會一直保持著高準位狀態。

The audio processor that has been addressed has to generate an Acknowledge after receiving each byte, otherwise, the SDA line will remain at the HIGH level during the ninth (9th) clock pulse. In this case, the master transmitter can generate the STOP information in order to abort the transfer.

SDA與SCL時序圖(Timing of SDA and SCL Bus Lines)

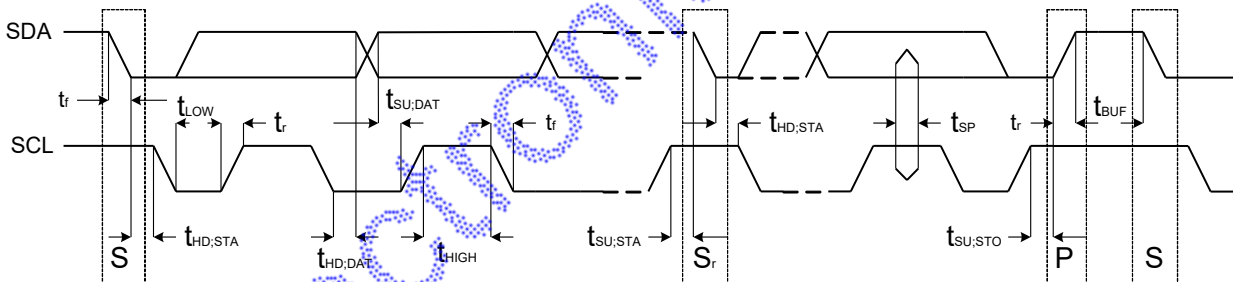

標準模式(Standard Mode)

符號 Symbol	參數 Parameter	最小值 Min.	最大值 Max.	單位 Unit
f_{SCL}	SCL clock frequency	0	100	kHz
$t_{HD:STA}$	Hold time (repeated) START condition. After this period, the first clock pulse is generated	4.0	-	us
t_{LOW}	LOW period of the SCL clock	4.7	-	us
t_{HIGH}	HIGH period of the SCL clock	4.0	-	us
$t_{SU:STA}$	Set-up time for a repeated START condition	4.7	-	us
$t_{HD:DAT}$	Data hold time: For I ² C-bus devices	0	3.45	us
$t_{SU:DAT}$	Data-set-up time	250	-	ns
t_r	Rise time of both SDA and SCL signals	-	1000	ns
t_f	Fall time of both SDA and SCL signals	-	300	ns
$t_{SU:STO}$	Set-up time for STOP condition	4.0	-	us
t_{BUF}	Bus free time between a STOP and START condition	4.7	-	us
C_b	Capacitive load for each bus line	-	400	pF
V_{nL}	Noise margin at the LOW level for each connected device (including hysteresis)	0.1V _{DD}	-	V
V_{nH}	Noise margin at the HIGH level for each connected device (including hysteresis)	0.2V _{DD}	-	V

匯流排介面(BUS INTERFACE)

藉由SDA和SCL匯流排，可讓微處理機將資料傳輸到MS6741。因此，SDA和SCL便構成此序列匯流排介面。Data are transmitted to and from the MCU to the MS6741 via the SDA and SCL. The SDA and SCL make up the BUS interface. It should be noted that pull-up resistors must be connected to the positive supply voltage.

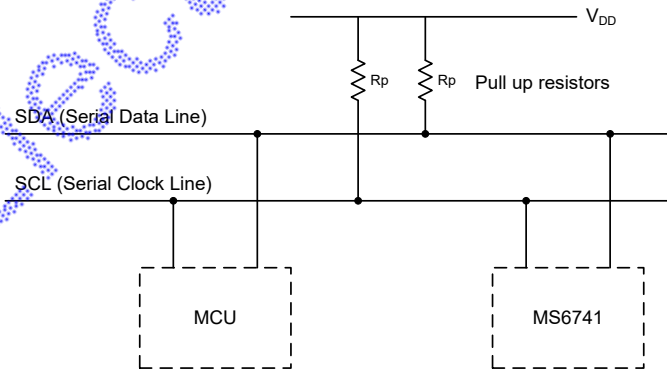

介面協定 (Interface Protocol)

I²C傳輸格式由以下要素所組成(The format consists of the following) :

- 起始位元。(A START condition.)
- 晶片位址位元組。(A chip address byte.)
- 認可位元 (ACK)。(Acknowledge bit.)
- 資料序列,N組 位元組+ACK。(A data sequence, N-bytes + Acknowledge.)
- 結束位元。(A STOP condition.)

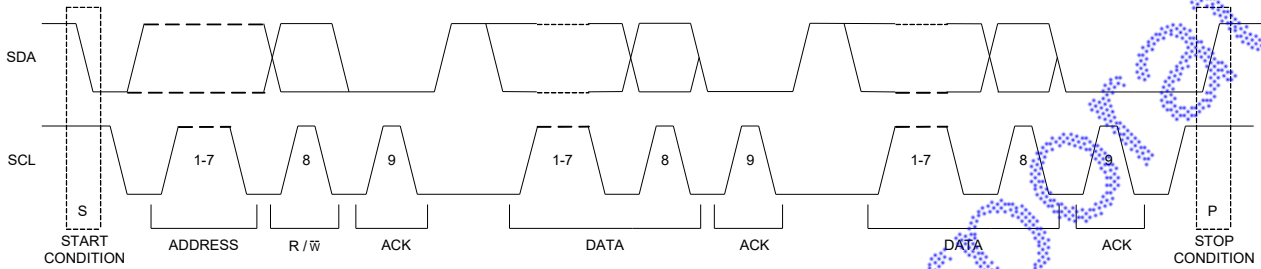

MS6741位址碼(MS6741 Address Code)

The chip address of the MS6741 is 88H.

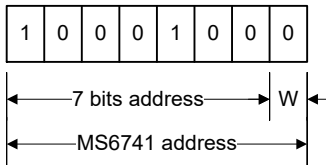

子位址描述(Sub-Address)

MSB								LSB		功能 Function
A7	A6	A5	A4	A3	A2	A1	A0			
				0	0	0	0	(00H)Main input selector and gain		
				0	0	0	1	(01H)Loudness		
				0	0	1	0	(02H)Volume		
				0	0	1	1	(03H)Bass		
				0	1	0	0	(04H)Treble		
				0	1	0	1	(05H)Mixing level control		
				0	1	1	0	(06H)Speaker attenuator left front		
				0	1	1	1	(07H)Speaker attenuator right front		
				1	0	0	0	(08H)Speaker attenuator left rear		
				1	0	0	1	(09H)Speaker attenuator right rear		
				1	0	1	0	(0AH)Subwoofer attenuator		
				1	0	1	1	(0BH)Rear speaker source / input gain / second input selector		
				1	1	0	0	(0CH)Soft mute / clock generator		
				1	1	0	1	(0DH)Mix and Subwoofer cut off frequency		

主輸入切換 / 增益控制(Main input selector / Input gain) (00H)

MSB					LSB			功能
D7	D6	D5	D4	D3	D2	D1	D0	Function
								輸入選擇 Input Selector
					0	0	0	QD/SE : QD
					0	0	1	SE IN1
					0	1	0	SE IN2
					0	1	1	SE IN3
					1	0	0	QD/SE : SE IN4
					1	0	1	Mute
					1	1	x	Mute
								輸入增益 Input Gain
	0	0	0	0				+0dB
	0	0	0	1				+1dB
	0	0	1	0				+2dB
	0	0	1	1				+3dB
	0	1	0	0				+4dB
	0	1	0	1				+5dB
	0	1	1	0				+6dB
	0	1	1	1				+7dB
	1	0	0	0				+8dB
	1	0	0	1				+9dB
	1	0	1	0				+10dB
	1	0	1	1				+11dB
	1	1	0	0				+12dB
	1	1	0	1				+13dB
	1	1	1	0				+14dB
	1	1	1	1				+15dB

響度(Loudness) (01H)

MSB				LSB				功能 Function
D7	D6	D5	D4	D3	D2	D1	D0	響度 Loudness
				0	0	0	0	-0dB
				0	0	0	1	-1dB
				0	0	1	0	-2dB
				0	0	1	1	-3dB
				0	1	0	0	-4dB
				0	1	0	1	-5dB
				0	1	1	0	-6dB
				0	1	1	1	-7dB
				1	0	0	0	-8dB
				1	0	0	1	-9dB
				1	0	1	0	-10dB
				1	0	1	1	-11dB
				1	1	0	0	-12dB
				1	1	0	1	-13dB
				1	1	1	0	-14dB
				1	1	1	1	-15dB
			0					Loudness ON
			1					Loudness Off
0								Loudness soft step on
1								Loudness soft step off

音量(Volume)(02H) /混音(Mix)(05H) /揚聲器衰減(Speaker attenuation) LF(06H)/ RF(07H)/LR(08H)/RR(09H)
/重低音(Subwoofer)(0AH)

MSB							LSB		功能
D7	D6	D5	D4	D3	D2	D1	D0	Function	
	0	0	0	1	1	1	1	+15dB	
	0	0	0	1	1	1	0	+14dB	
	:	:	:	:	:	:	:	:	
	0	0	0	0	0	0	0	0dB	
	0	0	1	0	0	0	0	0dB	
	0	0	1	0	0	0	1	-1dB	
	:	:	:	:	:	:	:	:	
	0	0	1	1	1	1	1	-15dB	
	0	1	0	0	0	0	0	-16dB	
	:	:	:	:	:	:	:	:	
	0	1	0	1	1	1	1	-31dB	
	0	1	1	0	0	0	0	-32dB	
	:	:	:	:	:	:	:	:	
	0	1	1	1	1	1	1	-47dB	
	1	0	0	0	0	0	0	-48dB	
	:	:	:	:	:	:	:	:	
	1	0	0	1	1	1	1	-63dB	
	1	0	1	0	0	0	0	-64dB	
	:	:	:	:	:	:	:	:	
	1	0	1	1	1	1	1	-79dB	
	1	1	X	X	X	X	X	Mute	
0								Soft step on	
1								Soft step off	

低音(Bass) (03H)

MSB				LSB				功能 Function
D7	D6	D5	D4	D3	D2	D1	D0	Gain/attenuation
			0	0	0	0	0	0dB
			0	0	0	0	1	-1dB
			0	0	0	1	0	-2dB
			0	0	0	1	1	-3dB
			0	0	1	0	0	-4dB
			0	0	1	0	1	-5dB
			0	0	1	1	0	-6dB
			0	0	1	1	1	-7dB
			0	1	0	0	0	-8dB
			0	1	0	0	1	-9dB
			0	1	0	1	0	-10dB
			0	1	0	1	1	-11dB
			0	1	1	0	0	-12dB
			0	1	1	0	1	-13dB
			0	1	1	1	0	-14dB
			0	1	1	1	1	-15dB
			1	0	0	0	0	0dB
			1	0	0	0	1	+1dB
			1	0	0	1	0	+2dB
			1	0	0	1	1	+3dB
			1	0	1	0	0	+4dB
			1	0	1	0	1	+5dB
			1	0	1	1	0	+6dB
			1	0	1	1	1	+7dB
			1	1	0	0	0	+8dB
			1	1	0	0	1	+9dB
			1	1	0	1	0	+10dB
			1	1	0	1	1	+11dB
			1	1	1	0	0	+12dB
			1	1	1	0	1	+13dB
			1	1	1	1	0	+14dB
			1	1	1	1	1	+15dB
0								Soft step on
1								Soft step off

高音(Treble)(04H)

MSB				LSB				功能 Function
D7	D6	D5	D4	D3	D2	D1	D0	
			0	0	0	0	0	Gain/attenuation 0dB
			0	0	0	0	1	-1dB
			0	0	0	1	0	-2dB
			0	0	0	1	1	-3dB
			0	0	1	0	0	-4dB
			0	0	1	0	1	-5dB
			0	0	1	1	0	-6dB
			0	0	1	1	1	-7dB
			0	1	0	0	0	-8dB
			0	1	0	0	1	-9dB
			0	1	0	1	0	-10dB
			0	1	0	1	1	-11dB
			0	1	1	0	0	-12dB
			0	1	1	0	1	-13dB
			0	1	1	1	0	-14dB
			0	1	1	1	1	-15dB
			1	0	0	0	0	0dB
			1	0	0	0	1	+1dB
			1	0	0	1	0	+2dB
			1	0	0	1	1	+3dB
			1	0	1	0	0	+4dB
			1	0	1	0	1	+5dB
			1	0	1	1	0	+6dB
			1	0	1	1	1	+7dB
			1	1	0	0	0	+8dB
			1	1	0	0	1	+9dB
			1	1	0	1	0	+10dB
			1	1	0	1	1	+11dB
			1	1	1	0	0	+12dB
			1	1	1	0	1	+13dB
			1	1	1	1	0	+14dB
			1	1	1	1	1	+15dB

次輸入切換 / 增益控制(Second input selector / Input gain) (0BH)

MSB					LSB			功能
D7	D6	D5	D4	D3	D2	D1	D0	Function
								次輸入選擇 Second Source Selector
					0	0	0	QD/SE : QD
					0	0	1	SE IN1
					0	1	0	SE IN2
					0	1	1	SE IN3
					1	0	0	QD/SE : SE IN4
					1	0	1	Mute
					1	1	x	Mute
								輸入增益 Input Gain
	0	0	0	0				+0dB
	0	0	0	1				+1dB
	0	0	1	0				+2dB
	0	0	1	1				+3dB
	0	1	0	0				+4dB
	0	1	0	1				+5dB
	0	1	1	0				+6dB
	0	1	1	1				+7dB
	1	0	0	0				+8dB
	1	0	0	1				+9dB
	1	0	1	0				+10dB
	1	0	1	1				+11dB
	1	1	0	0				+12dB
	1	1	0	1				+13dB
	1	1	1	0				+14dB
	1	1	1	1				+15dB
								後揚聲器輸入選擇 Rear Speaker Source
0								Main source
1								Second source

Soft-step時間控制(Soft-step time) (0CH)

MSB				LSB				功能 Function
D7	D6	D5	D4	D3	D2	D1	D0	
								Soft step time
	0	0	0					0.64ms
	0	0	1					1.26ms
	0	1	0					2.64ms
	0	1	1					5.12ms
	1	0	0					12.2ms
	1	0	1					20.6ms
	1	1	0					40.6ms
	1	1	1					81.4ms

重低音與混音(Subwoofer and mix)(0DH)

MSB				LSB				功能 Function
D7	D6	D5	D4	D3	D2	D1	D0	
								Mix
		0						Mixing Enable on
		1						Mixing Enable off
	0							Mixing to LF on
	1							Mixing to LF off
0								Mixing to RF on
1								Mixing to RF off
								Subwoofer cut off frequency
					0	x		80Hz
					1	0		120Hz
					1	1		160Hz
							0	Release Vref to GND
							1	Release Vref to 1/2Vdd

*Mixing Enable off means pin 31 as 2nd subwoofer output.

Soft-step功能(Soft-step)

當音量改變時，輸出可能聽見不悅耳的聲差，那是由於電位的劇烈變化所產生。

When the volume-level is changed audible clicks could appear at the output.

Soft-step功能則能圓滑此變化，尤其是音量改變較大的時候效果更為顯著。

The root cause of those clicks could be the sudden change of the envelope of the audio signal. With the Soft-step feature, this click could be reduced to a minimum.

Soft-step不僅在1dB時適用，亦支援N dB的情況以及Mute。

Soft-step supports N dB volume change, including mute.

範例(Example)

Soft-Step Time = 5.12ms

0dB → -16dB → 0dB

Vin = 1Vrms @ 1KHz

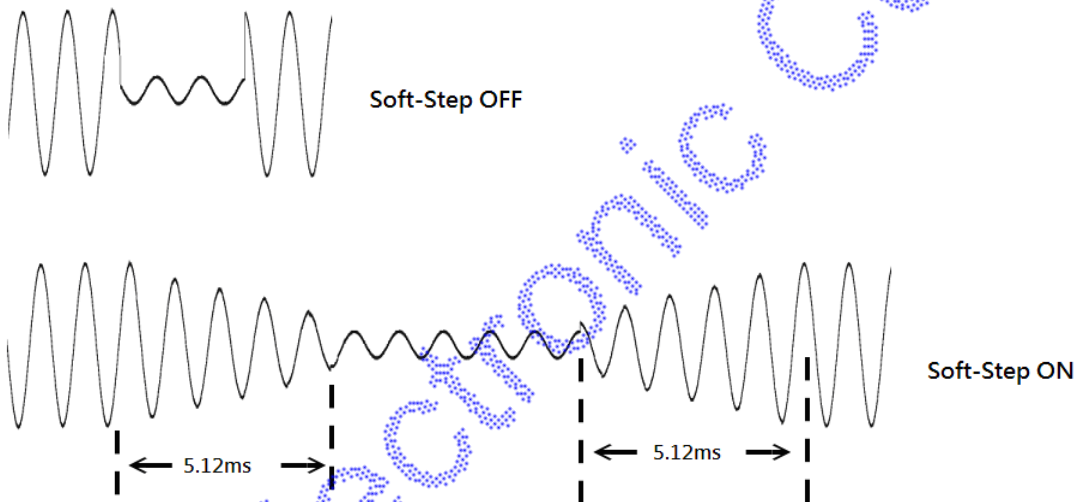

Vin = 1Vrms @ 2KHz

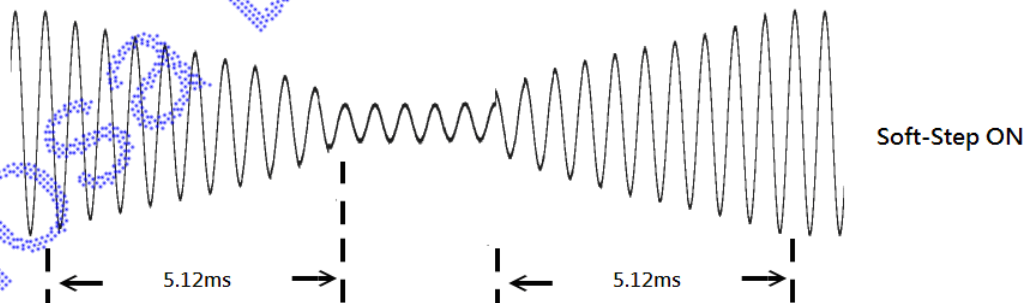

+8dB → -16dB → +8dB

Vin = 0.5Vrms @ 1KHz

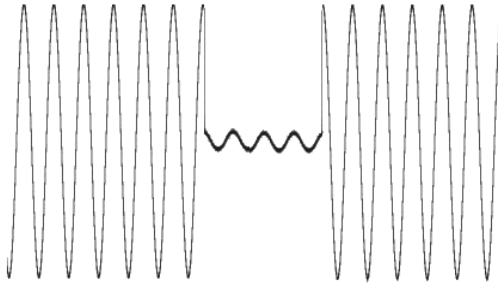

Soft-Step OFF

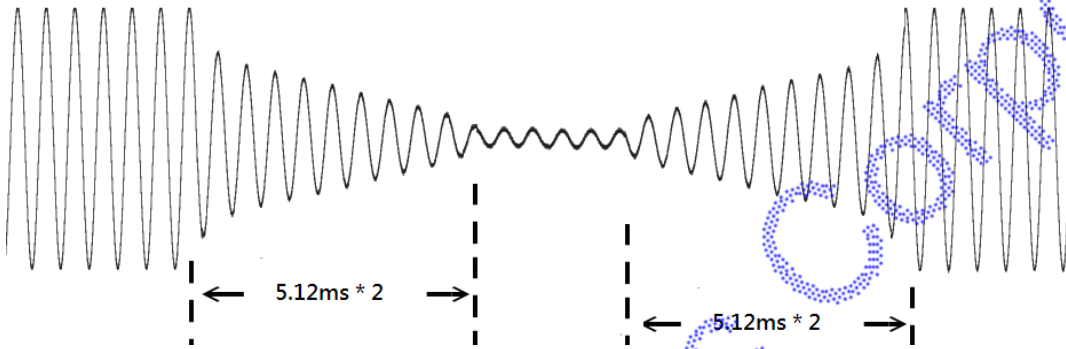

Soft-Step ON

5.12ms * 2

5.12ms * 2

0dB → Mute → 0dB

Vin = 1Vrms @ 1KHz

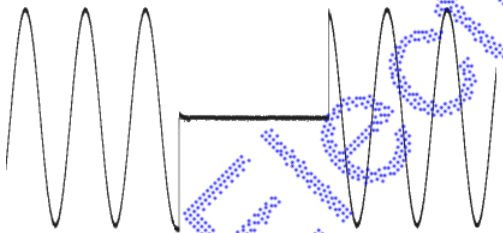

Soft-Step OFF

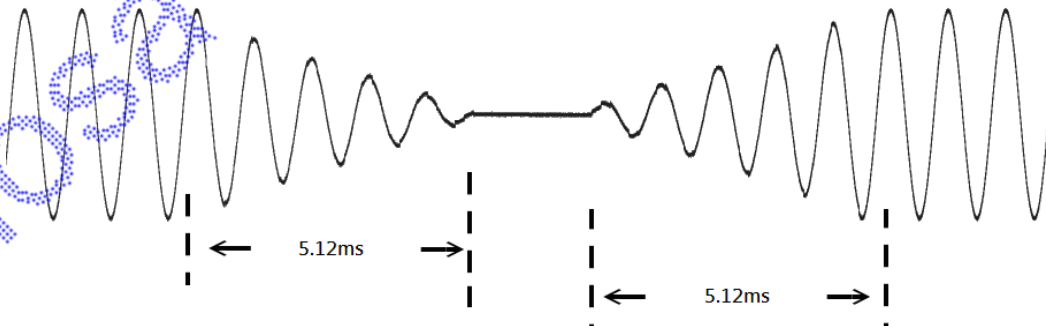

Soft-Step ON

5.12ms

5.12ms

應用資訊(APPLICATION INFORMATION)

基本應用範例(Basic application example)

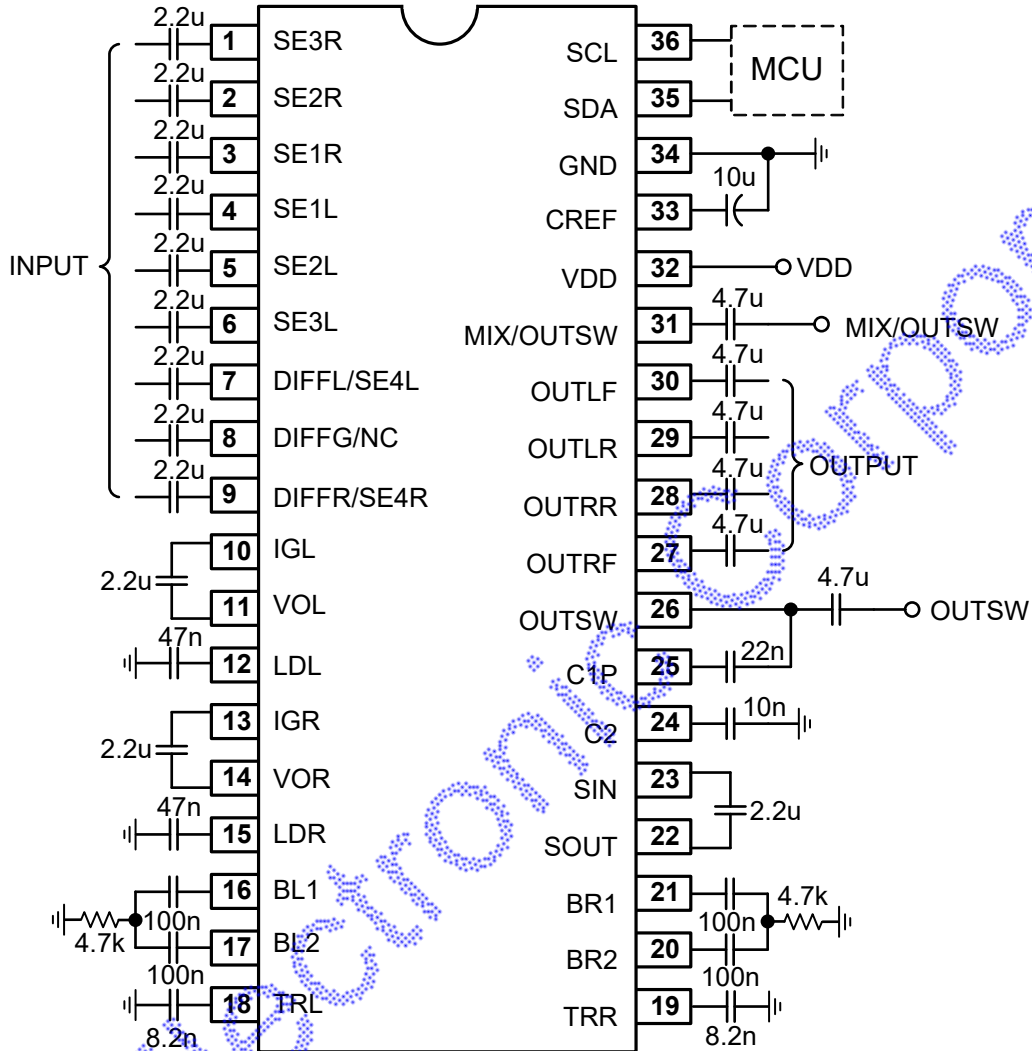

封裝尺寸(EXTERNAL DIMENSIONS)

SSOP36 (300mil)

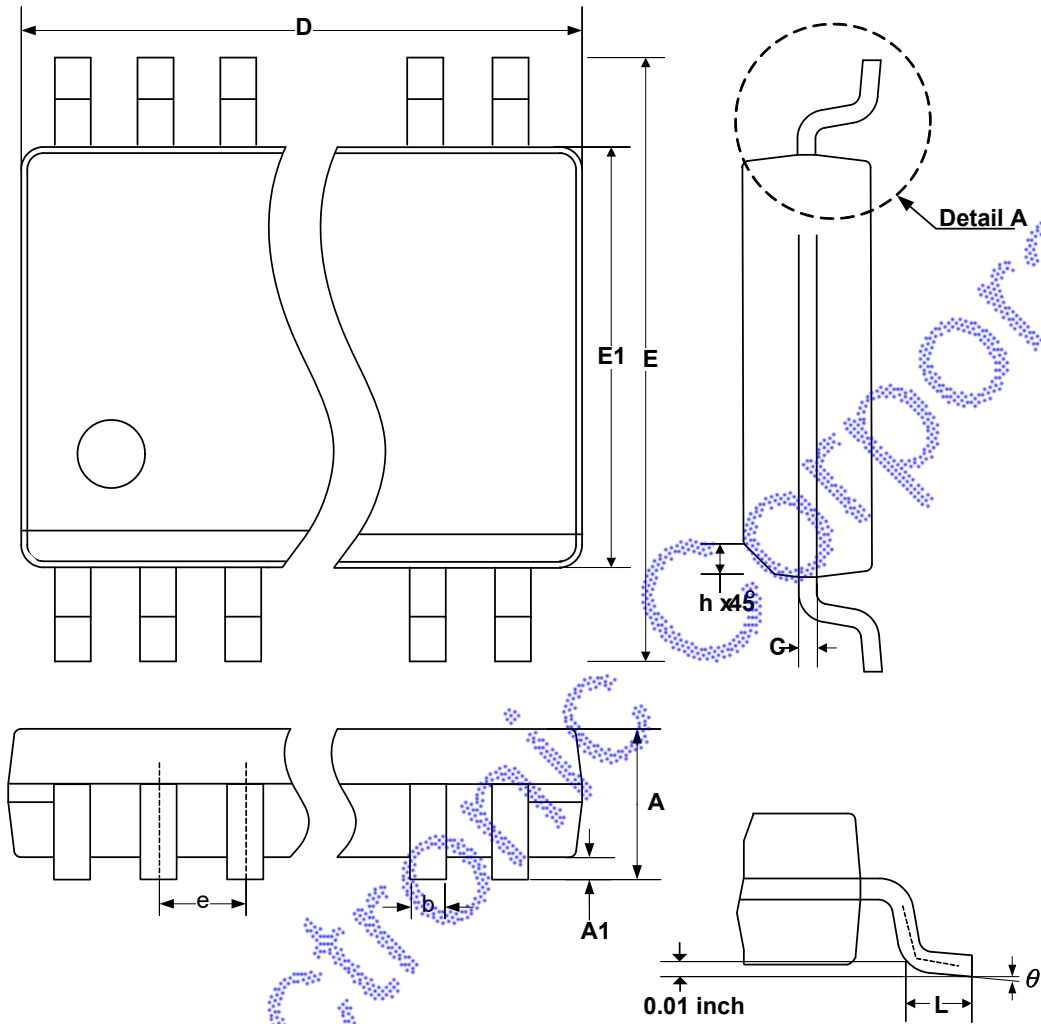

Symbol	Dimension in mm			Dimension in inch		
	MIN.	NOM.	MAX.	MIN.	NOM.	MAX.
A	2.413	2.591	2.794	0.095	0.102	0.110
A1	0.203	0.305	0.406	0.008	0.012	0.016
b	0.30		0.45	0.012		0.018
c	0.127		0.254	0.005		0.010
e	0.8 BASIC			0.032 BASIC		
E	10.033		10.668	0.395		0.420
E1	7.391	7.493	7.595	0.291	0.295	0.299
h	0.381		0.635	0.015		0.025
L	0.508		1.016	0.020		0.040
θ	0°		8°	0°		8°
D	15.748	15.875	16.002	0.620	0.625	0.630