

# Dual 2W Power Amplifiers / Stereo Headphone Low Voltage, Pop Noise Free Function

## FEATURES

- Operation range: 2.4V ~ 6.5V
- Shutdown Current 0.4uA at 5V
- Output power, THD+N=1%  
 BTL,  $R_L=3\Omega$ , 2.3W at 5V  
 BTL,  $R_L=4\Omega$ , 2W at 5V, 0.8W at 3.3V, 500mW at 2.7V  
 BTL,  $R_L=8\Omega$ , 1.2W at 5V, 0.5W at 3.3V, 350mW at 2.7V  
 SE,  $R_L=8\Omega$ , 300mW at 5V, 130mW at 3.3V, 85mW at 2.7V  
 SE,  $R_L=32\Omega$ , 90mW at 5V, 40mW at 3.3V, 25mW at 2.7V
- Headphone sense
- Unity-gain stable
- pop noise free control (extra function for pin7)
- Space-saving TSSOP20, enhance thermal pad

## APPLICATIONS

- Desktop computer's sound card
- Portable audio devices
- Portable digital TV
- MP3 peripheral
- Handheld games
- Cross-reference:  
 LM4863

## DESCRIPTION

The MS6863 is a low distortion power amplifier that can drive 2\*2W of continuous average power into a dual 4Ω bridged-tied load (BTL) or 2 \* 90mW into stereo 32Ω single ended (SE) loads headphone. It can automatically switch between dual BTL and stereo SE modes utilizing a headphone sense pin. The BTL configuration eliminates the need for external coupling capacitors on the output in most applications. The unity gain stable MS6863's gain is set by external gain-setting resistors.

The MS6863 has good feature for portable equipment, these features include the low voltage operation, micropower consumption shutdown mode, enhance thermal pad and small package TSSOP20, make the MS6863 ideally suited for use in portable audio equipments. The MS6863 has an extra selection for pin7 to achieve pop noise free in shutdown control.

## BLOCK DIAGRAM

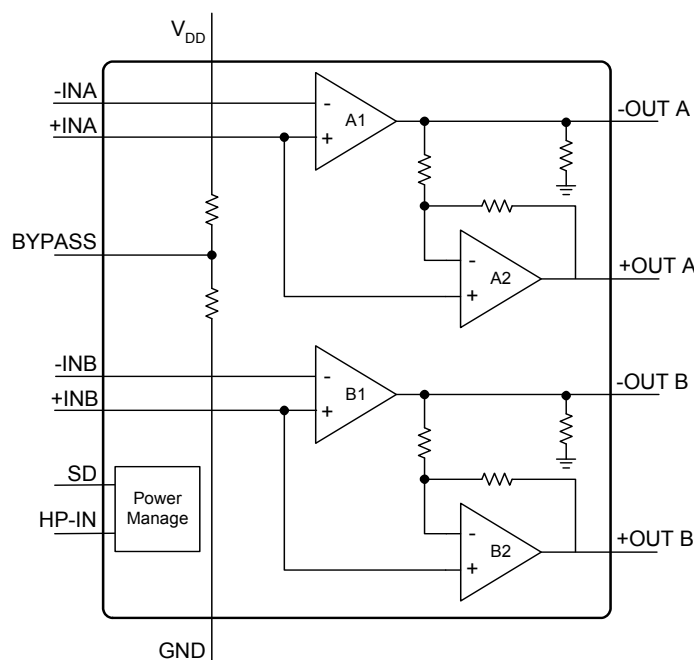

## PIN CONFIGURATION

Symbol	Pin	Description
SD	1	SHUTDOWN places the entire device in shutdown mode when held high. TTL compatible input.
+OUTA	3	Bridged-tied load positive output A.
-OUTA	5	Left channel output or bridged-tied load negative output A.
-INA	6	Negative input A.
+INA	8	Positive input A.
+INB	13	Positive input B.
BYPASS	14	BYPASS is a capacitor to the voltage divider for the internal mid-supply bias. This terminal should be connected to a 0.1- $\mu$ F to 10- $\mu$ F capacitor $C_B$ .
-INB	15	Negative input B
-OUTB	16	Right channel output or bridged-tied load negative output B.
+OUTB	18	Bridged-tied load positive output B.
HP-IN	20	Headphone input detection. A logical low sets BTL mode, a logical high sets SE mode.
VDD	4, 17	Supply voltage
GND	2, 9, 10 11, 12, 19	Ground
GND (SDPR)	7	Connected to ground, it is compatible for LM4863 SDPR: Shutdown Power Preparation. Pop noise free in shutdown control, please refer to application information

### TSSOP20

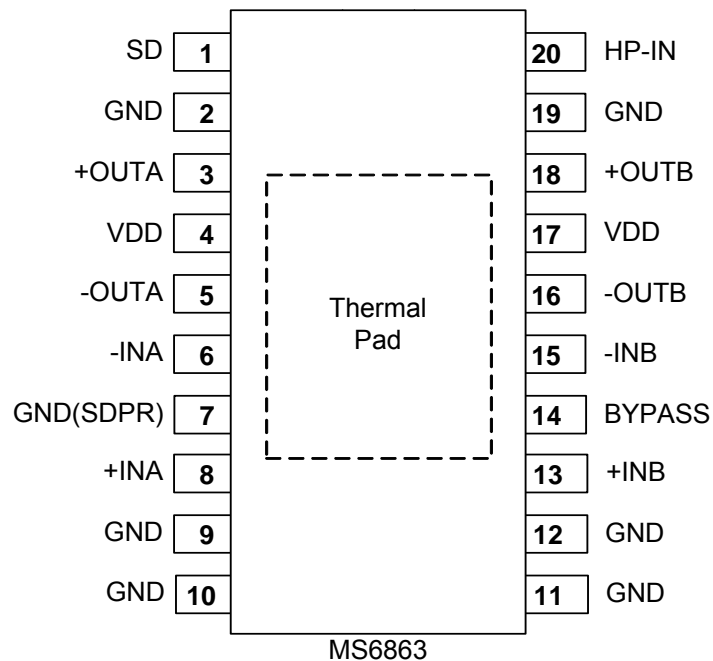

## ORDERING INFORMATION

Package	Part number	Packaging Marking	Transport Media
20Pin TSSOP (lead free)	MS6863TGTR	MS6863G	2.5k Units Tape and Reel
20Pin TSSOP (lead free)	MS6863TGU	MS6863G	75 Units Tube

RoHS Compliance

## ABSOLUTE MAXIMUM RATINGS

Symbol	Parameter	Rating	Unit
V <sub>DD</sub>	Supply voltage	6.5	V
V <sub>ESD</sub>	Electrostatic handling	2000	V
T <sub>STG</sub>	Storage temperature range	-65 to 150	°C
T <sub>A</sub>	Operating ambient temperature range	-40 to 85	°C
T <sub>J</sub>	Maximum junction temperature	150	°C
T <sub>S</sub>	Soldering temperature, 10 seconds	260	°C
R <sub>THJA</sub>	Thermal resistance from junction to ambient in free air TSSOP20 (enhance thermal pad)	51	°C/W

## OPERATING RATINGS

Symbol	Parameter	Min	Typ	Max	Unit
V <sub>DD</sub>	Supply voltage	2.4	5	6.5	V

### 5V ELECTRICAL CHARACTERISTICS

T<sub>a</sub> = 25°C, V<sub>DD</sub>=5V, f=1kHz, BW<30kHz, unless otherwise specified.

Symbol	Parameter	Conditions	Min	Typ	Max	Unit
I <sub>Q</sub>	Quiescent current	BTL Mode, V <sub>IN</sub> =0V, I <sub>O</sub> =0A	4.5	5.8	8.3	mA
		SE Mode, V <sub>IN</sub> =0V, I <sub>O</sub> =0A	2.5	3.2	4.2	mA
I <sub>SD</sub>	Shutdown current	SD Mode, V <sub>SD</sub> =V <sub>DD</sub>	-	0.4	2	uA
V <sub>SDH</sub>	Shutdown input voltage high		2.0	-	-	V
V <sub>SDL</sub>	Shutdown input voltage low		-	-	0.8	V
V <sub>HPINH</sub>	HP-IN input voltage high	Hysteresis voltage	0.6V <sub>DD</sub>	-	-	V
V <sub>HPINL</sub>	HP-IN input voltage low		-	-	0.4V <sub>DD</sub>	V
CS	Channel separation	BTL Mode, R <sub>L</sub> =8Ω P <sub>O</sub> =1W	-	95	-	dB
		SE Mode, R <sub>L</sub> =32Ω P <sub>O</sub> =60mW	-	90	-	dB
PSRR	Power supply rejection ratio	BTL Mode, R <sub>L</sub> =8Ω C <sub>BP</sub> =1uF, f=100Hz	-	63	-	dB
		SE Mode, R <sub>L</sub> =32Ω C <sub>BP</sub> =10uF, f=100Hz	-	55	-	dB
THD+N	Total harmonic distortion plus noise	SE mode, R <sub>L</sub> =32Ω, 75mW	-	-77	-72	dB
			-	0.01412	0.0251	%
S/N	Signal-to-noise ratio	SE mode, A-weighting, 75mW	98	103	-	dB
P <sub>o</sub>	Output power	BTL Mode, R <sub>L</sub> = 3Ω THD+N = 1%	-	2.3	-	W
		BTL Mode, R <sub>L</sub> = 4Ω THD+N = 1%	-	2	-	W
		BTL Mode, R <sub>L</sub> = 8Ω THD+N = 1%	-	1.3	-	W
		SE Mode, R <sub>L</sub> = 8Ω THD+N = 1%	-	300m	-	W
		SE Mode, R <sub>L</sub> = 32Ω THD+N = 1%	-	90m	-	W

### 3.3 V ELECTRICAL CHARACTERISTICS

Ta = 25°C, V<sub>DD</sub>=3.3V, f=1kHz, BW<30kHz, unless otherwise specified.

Symbol	Parameter	Conditions	Min	Typ	Max	Unit
I <sub>Q</sub>	Quiescent current	BTL Mode, V <sub>IN</sub> =0V, I <sub>O</sub> =0A	-	5.4	-	mA
		SE Mode, V <sub>IN</sub> =0V, I <sub>O</sub> =0A	-	2.8	-	mA
I <sub>SD</sub>	Shutdown current	SD Mode, V <sub>SD</sub> =V <sub>DD</sub>	-	0.2	-	uA
CS	Channel separation	BTL Mode, R <sub>L</sub> =8Ω P <sub>o</sub> =120mW	-	83	-	dB
		SE Mode, R <sub>L</sub> =32Ω P <sub>o</sub> =25mW	-	86	-	dB
PSRR	Power supply rejection ratio	BTL Mode, R <sub>L</sub> =8Ω C <sub>BP</sub> =1uF, f=100Hz	-	60	-	dB
		SE Mode, R <sub>L</sub> =32Ω C <sub>BP</sub> =10uF, f=100Hz	-	53	-	dB
THD+N	Total harmonic distortion plus noise	SE mode, R <sub>L</sub> =32Ω, 25mW	-	-73	-68	dB
			0.0238	0.0398	%	
S/N	Signal-to-noise ratio	SE mode, A-weighting 25mW	94	99	-	dB
P <sub>o</sub>	Output power	BTL Mode, R <sub>L</sub> = 4Ω THD+N = 1%	-	0.8	-	W
		BTL Mode, R <sub>L</sub> = 8Ω THD+N = 1%	-	0.5	-	W
		SE Mode, R <sub>L</sub> = 8Ω THD+N = 1%	-	130m	-	W
		SE Mode, R <sub>L</sub> = 32Ω THD+N = 1%	-	40m	-	W

### 2.7 V ELECTRICAL CHARACTERISTICS

Ta = 25°C, V<sub>DD</sub>=2.7V, f=1kHz, BW<30kHz, unless otherwise specified.

Symbol	Parameter	Conditions	Min	Typ	Max	Unit
I <sub>Q</sub>	Quiescent current	BTL Mode, V <sub>IN</sub> =0V, I <sub>O</sub> =0A	-	5.1	-	mA
		SE Mode, V <sub>IN</sub> =0V, I <sub>O</sub> =0A	-	2.7	-	mA
I <sub>SD</sub>	Shutdown current	SD Mode, V <sub>SD</sub> =V <sub>DD</sub>	-	0.1	-	uA
CS	Channel separation	BTL Mode, R <sub>L</sub> =8Ω Po=80mW	-	83	-	dB
		SE Mode, R <sub>L</sub> =32Ω Po=15mW	-	85	-	dB
PSRR	Power supply rejection ratio	BTL Mode, R <sub>L</sub> =8Ω C <sub>BP</sub> =1uF, f=100Hz	-	60	-	dB
		SE Mode, R <sub>L</sub> =32Ω C <sub>BP</sub> =10uF, f=100Hz	-	52	-	dB
THD+N	Total harmonic distortion plus noise	SE mode, R <sub>L</sub> =32Ω, 15mW	-	-71	-66	dB
			0.028	0.051	%	
S/N	Signal-to-noise ratio	SE mode, A-weighting 15mW	90	97	-	dB
Po	Output power	BTL Mode, R <sub>L</sub> = 4Ω THD+N = 1%	-	0.5	-	W
		BTL Mode; R <sub>L</sub> = 8Ω THD+N = 1%	-	0.35	-	W
		SE Mode; R <sub>L</sub> = 8Ω THD+N = 1%	-	85m	-	W
		SE Mode; R <sub>L</sub> = 32Ω THD+N = 1%	-	25m	-	W

### 2.4 V ELECTRICAL CHARACTERISTICS

Ta = 25°C, V<sub>DD</sub>=2.4V, f=1kHz, BW<30kHz, unless otherwise specified.

Symbol	Parameter	Conditions	Min	Typ	Max	Unit
THD+N	Total harmonic distortion plus noise	SE mode, R <sub>L</sub> =32Ω, 15mW	-	-71	-65	dB
			0.028	0.056	%	
S/N	Signal-to-noise ratio	SE mode, A-weighting 15mW	90	97	-	dB
Po	Output power	BTL Mode, R <sub>L</sub> = 4Ω THD+N = 1%	-	0.375	-	W
		BTL Mode; R <sub>L</sub> = 8Ω THD+N = 1%	-	0.27	-	W
		SE Mode; R <sub>L</sub> = 8Ω THD+N = 1%	-	72m	-	W
		SE Mode; R <sub>L</sub> = 32Ω THD+N = 1%	-	22m	-	W

## TYPICAL PERFORMANCE CHARACTERISTICS

Ta = 25°C, BW < 30kHz, unless otherwise specified.

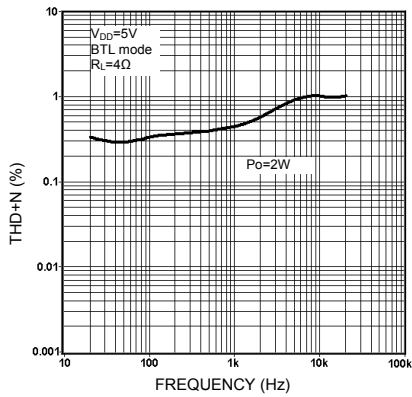

THD+N vs. frequency

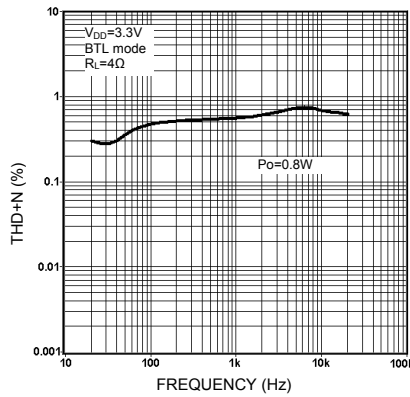

THD+N vs. frequency

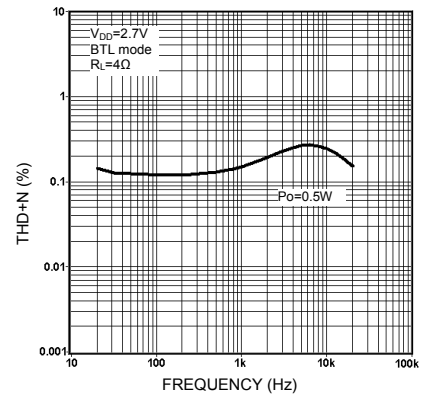

THD+N vs. frequency

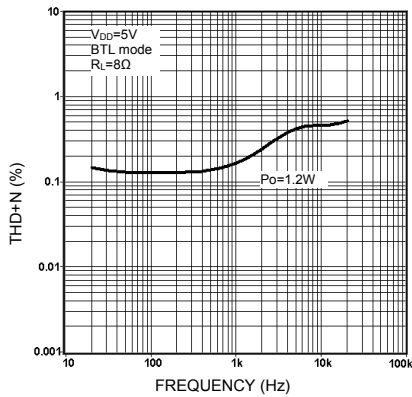

THD+N vs. frequency

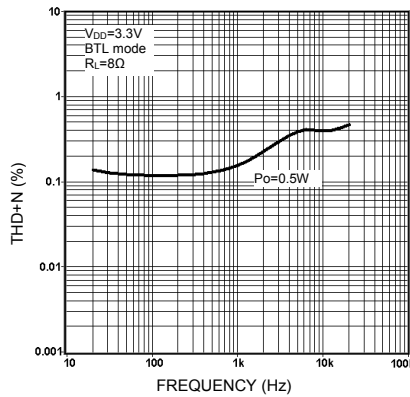

THD+N vs. frequency

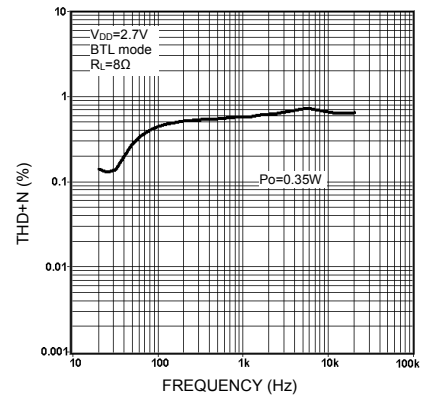

THD+N vs. frequency

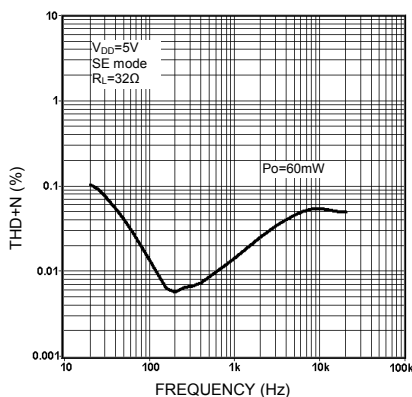

THD+N vs. frequency

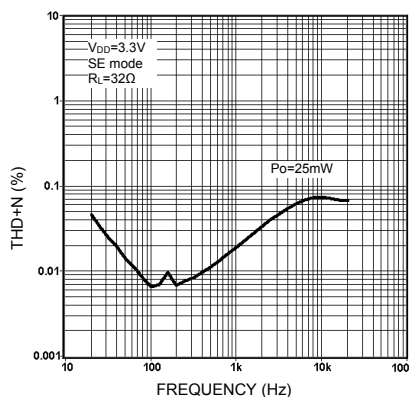

THD+N vs. frequency

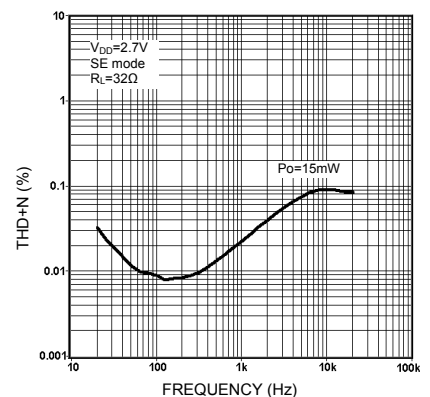

THD+N vs. frequency

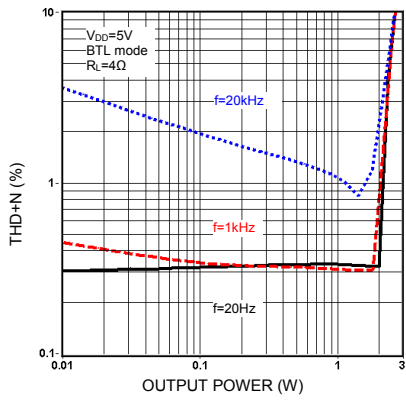

THD+N vs. output power

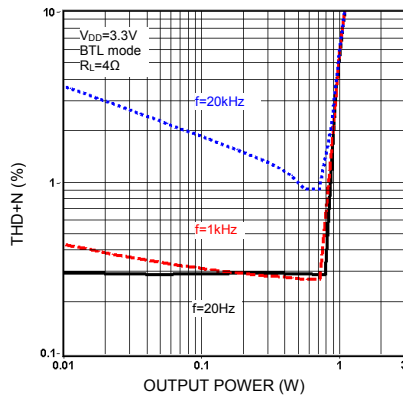

THD+N vs. output power

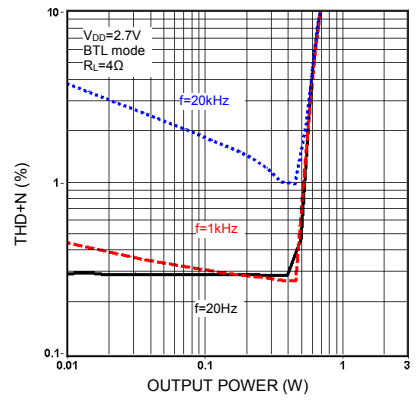

THD+N vs. output power

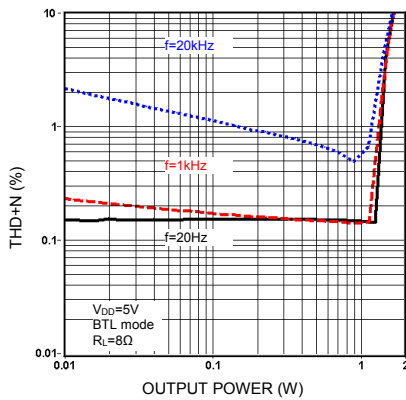

THD+N vs. output power

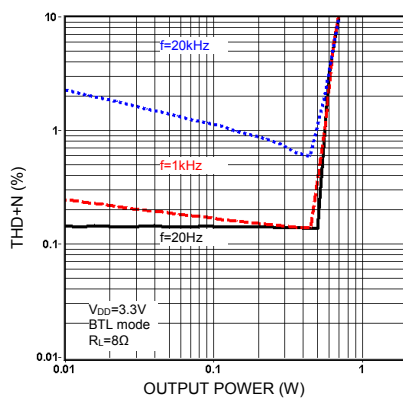

THD+N vs. output power

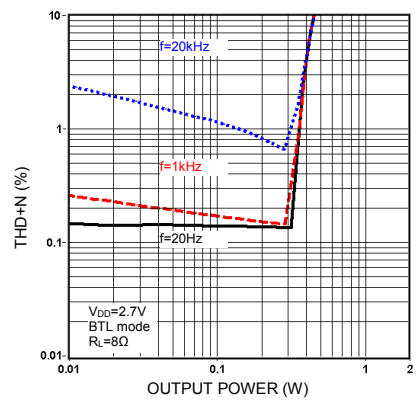

THD+N vs. output power

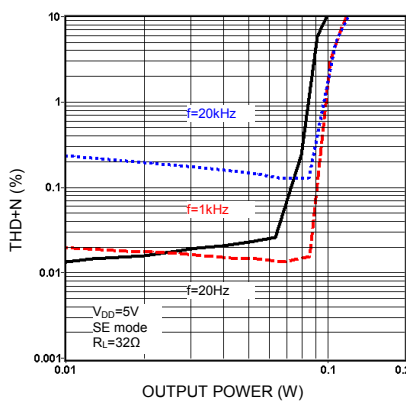

THD+N vs. output power

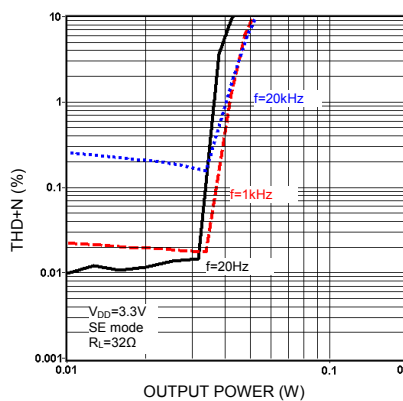

THD+N vs. output power

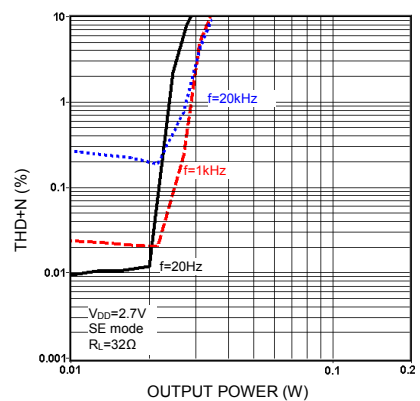

THD+N vs. output power



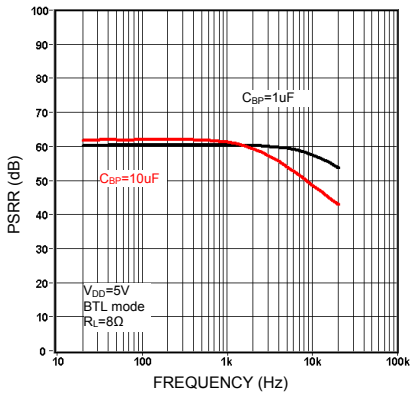

PSRR vs. frequency

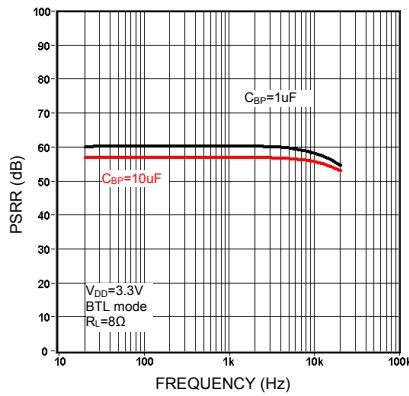

PSRR vs. frequency

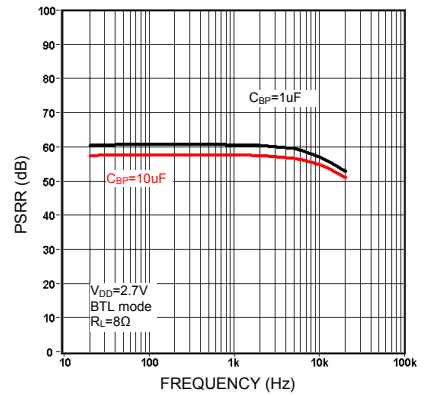

PSRR vs. frequency

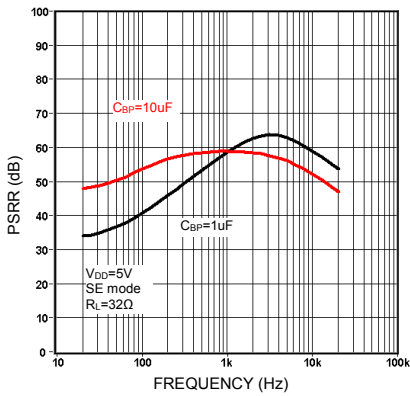

PSRR vs. frequency

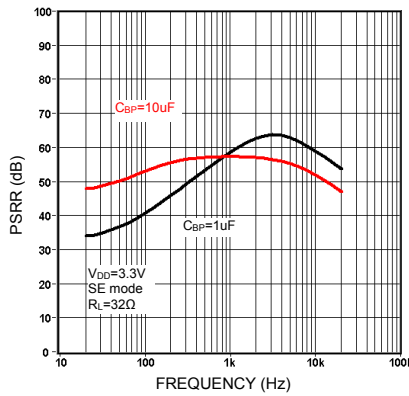

PSRR vs. frequency

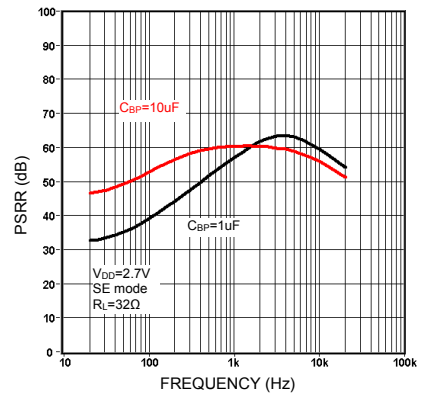

PSRR vs. frequency

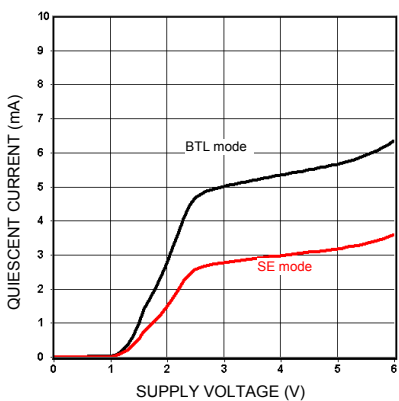

Quiescent current vs. supply voltage

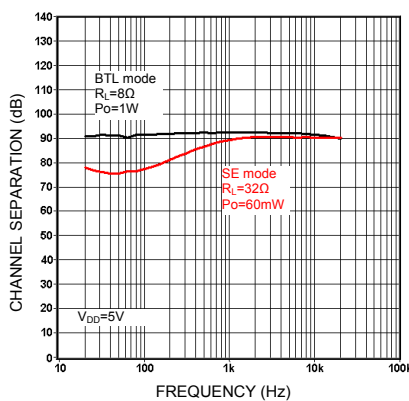

Channel separation vs. frequency

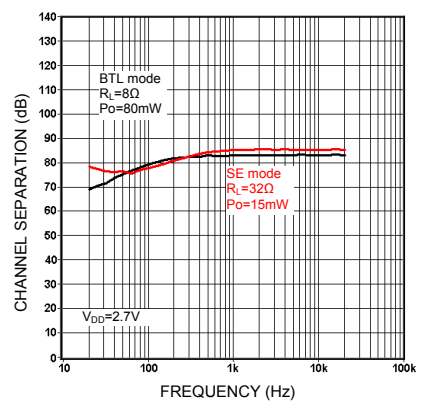

Channel separation vs. frequency

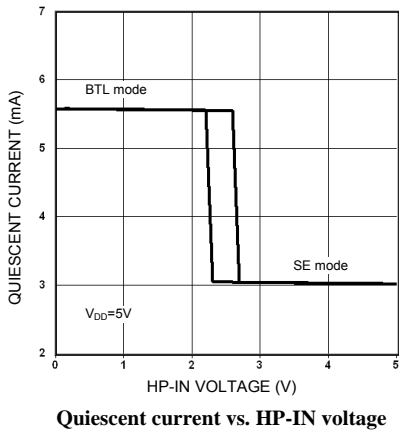

## APPLICATION INFORMATION

### Application example

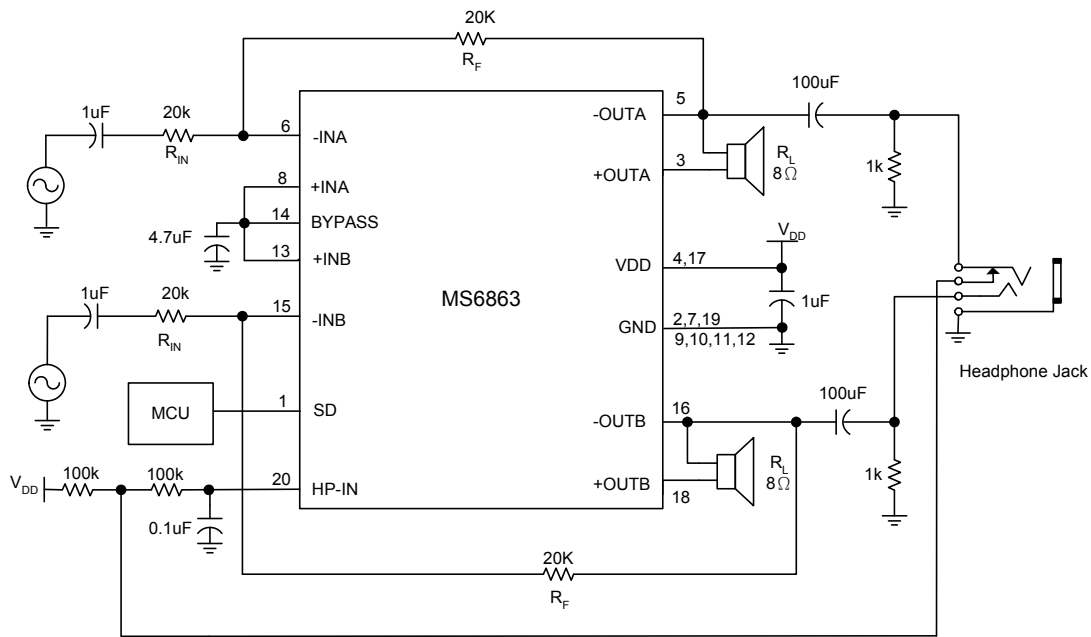

$$\text{DC Gain} = -R_F / R_{IN} = -1$$

**Fig.1 A audio amplifier application circuit.**

### SE mode and BTL mode operation

As shown in block diagram and Fig.1, in the SE mode, the MS6863 operates as high current output dual operational amplifiers. Amplifiers A1 and B1 are independent amplifiers with an externally configured gain of  $A_V = -R_F/R_{IN}$ . As amplifiers A2 and B2 are shutdown, then the amplifiers will be a high output impedance state.

In BTL mode, the audio signal from the -INA (-INB) pin is directed to the inverting input of A1(B1). The A2(B2) is then activated with a closed-loop gain of  $A_V = -1$  fixed by two internal resistors. The outputs of A1(B1) and A2(B2) are then used to drive the bridged-tied load.

### HP-IN operation

The ability of the MS6863 is easily switched between dual BTL and stereo SE modes. The mode is switched by the headphone control pin, HP-IN. A logic-high activates the SE mode when a set of headphones plugged into the system, on the other hand, a logical-low to HP-IN activates the BTL mode when no headphones. Please note that this HP-IN voltage is a hysteresis voltage, the control voltage range is  $0.4V_{DD}$  to  $0.6V_{DD}$ .

### SHUTDOWN mode

SD places the entire device in shutdown mode when held high.

### Thermal pad considerations

The thermal pad must be connected to ground. The package with thermal pad of the MS6863 requires the special attention on thermal design. The thermal pad on the bottom of the MS6863 should be soldered down to a copper pad on the circuit board. Heat can be conducted away from the thermal pad through the copper plane to ambient. If the copper plane is not on the top surface of the circuit board, 9 vias of 13 mil or smaller in diameter should be used to thermally couple the thermal pad to the bottom plane. For good thermal conduction, the vias must be plated through and solder filled.

### Pop noise free example

Use extra function of pin7 and control timing.

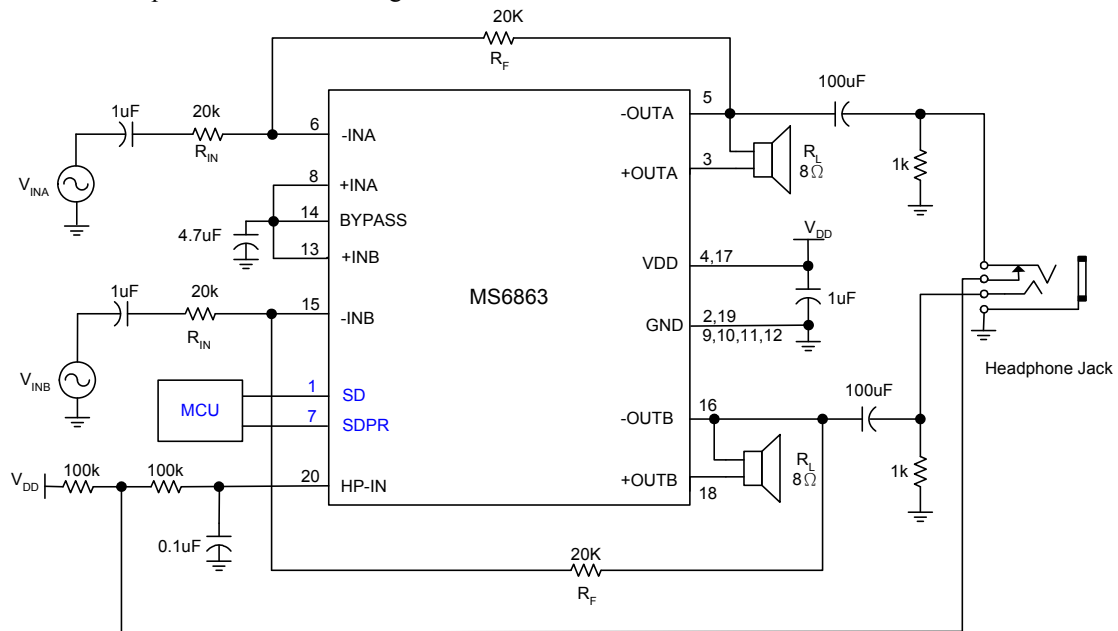

**Fig.2 A pop noise free application circuit.**

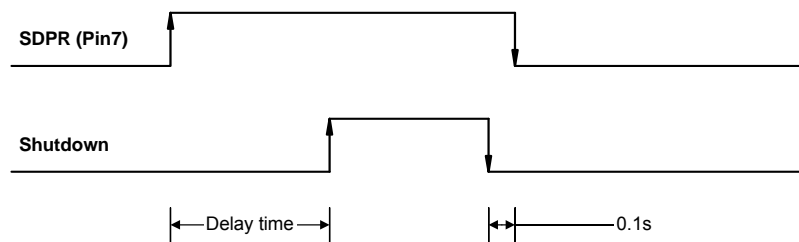

**Fig.3 A control timing for pop noise free**

### Pop noise free in shutdown control

According to the control timing figure3, it can reduce pop noise efficiently during the shutdown control. The timing can be applied to BTL and SE mode. The delay time is decided by the value of the bypass capacitor.

### EXTERNAL DIMENSIONS

#### TSSOP20 (Thermal Pad)

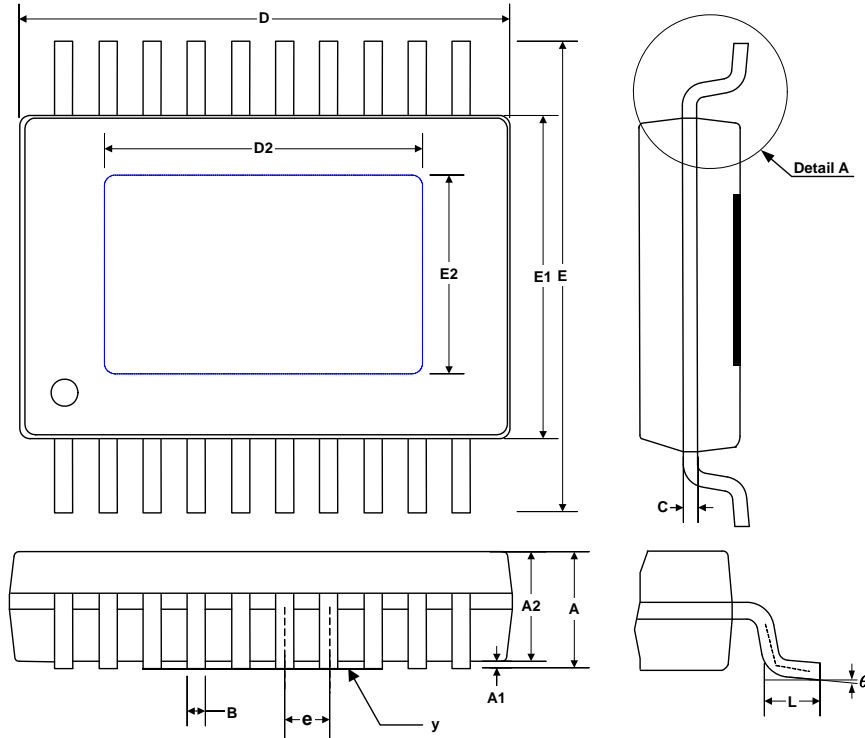

Symbol	Dimension in mm			Dimension in inches		
	Min	Nom	Max	Min	Nom	Max
A	0.80	-	1.15	0.031	-	0.045
A1	0.00	-	0.10	0.000	-	0.004
A2	0.80	1.00	1.05	0.031	0.039	0.041
b	0.19	-	0.30	0.007	-	0.012
C	0.09	-	0.20	0.004	-	0.008
D	6.40	6.50	6.60	0.252	0.256	0.260
D2	3.70	3.80	3.90	0.146	0.150	0.154
E	6.20	6.40	6.60	0.244	0.252	0.260
E1	4.30	4.40	4.50	0.169	0.173	0.177
E2	2.70	2.80	2.90	0.106	0.110	0.114
e	0.650 BASIC			0.026 BASIC		
L	0.45	0.60	0.75	0.018	0.024	0.030
θ	0°	-	8°	0°	-	8°
y	-	-	0.10	-	-	0.004

## DEMO BOARD

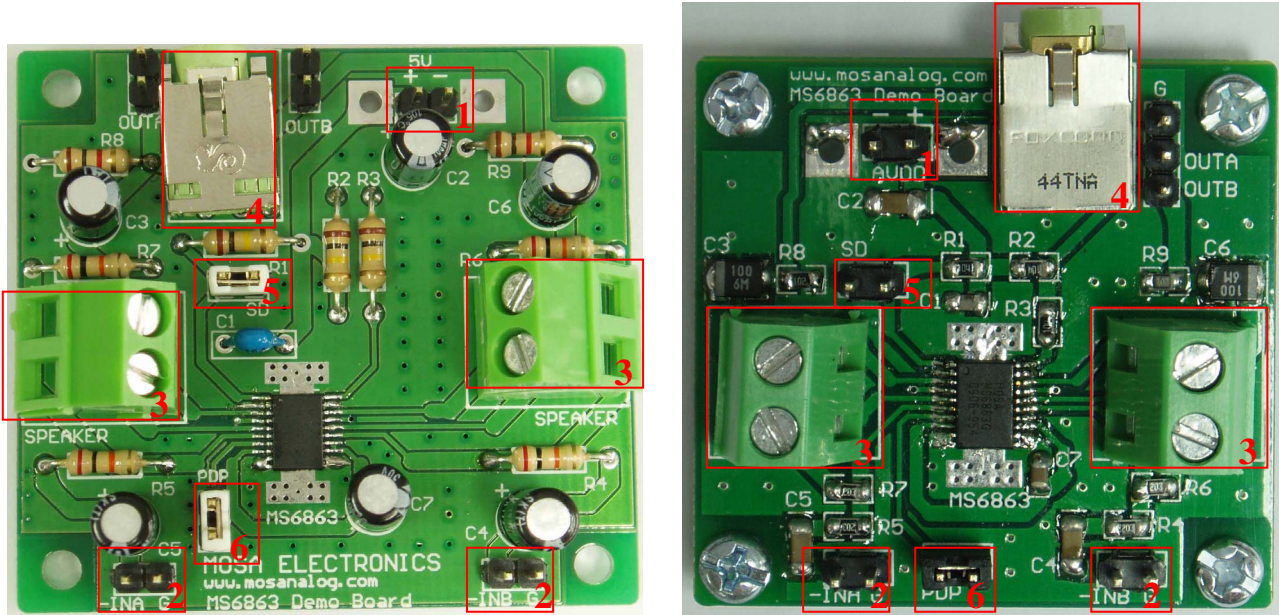

### Function description

Label 1: Supply Input

Supply voltage range is 2.4V to 6.5V, the left of jump is positive and the right of jump is negative.

Label 2: Signal Input

Connected to audio signals.

Label 3: Speaker Output

Connected to speaker with 8ohm or 4 ohm

Label 4: Headphone Jack

Used 3.5mm diameter of headphone with 32ohm

Label 5: Shutdown Control

System is active mode when jump is close, system enters shutdown mode when jump is open.

Label 6: Shutdown Power Preparation

It is compatible for LM4863 when jump is close. This is the same as connect to ground.

When jump is open, it can be used the extra function of the MS6863. The details please refer to application information.

### SE mode and BTL mode operation

The headphone controls operational mode. System enters SE mode when headphone jack is empty.

When a set of headphone plugged into the jack, the system switched to BTL mode.

## Circuit

